



**Manual
Starlogger Field Termination Strip
and
Signal Conditioning Modules**

Models

**6103, 6507, 6104, 6105, 6106, 6107, 6108, 6109, 6110, 6114, 6117, 6140,
6141 & 6142**

Revision History

File name / Revision	Date	Authors
Previous version BX	2004	RS/ JH
Unidata Manual - 6103 6507 6104 6105 6106 6107 6108 6109 6110 6114 6117 6140 6141 6142 Starlogger FTS & Sig Cond Issue 2.0 (decrypted)	2007	AB/CB/JH/MS/KC

Copyright © Unidata Pty Ltd 2000-2008. All rights reserved. No part of this publication may be reproduced, transmitted, transcribed, stored in a retrieval system, or translated into any spoken or computer language, in any form or by any means. Electronic, mechanical, magnetic, optical, chemical, manual or otherwise, without prior written permission of Unidata Pty Ltd 40 Ladner St, O'Connor Western Australia 6163.

Table of Contents

1. INTRODUCTION	1
1.1 How to Use This Supplement	2
2. INSTALLATION OF FRAME & STRIP	3
2.1 Model 6103C - Mounting Frame	3
2.2 Installation of Mounting Frame	4
2.3 Installation of Field Termination Strip	4
3. TERMINATIONS	5
3.1 Special Purpose Modules	7
3.2 Links	8
4. SIGNAL DESCRIPTION	11
4.1 Log Start Sense (Link LS)	11
4.2 Analog Inputs	11
4.3 Counters	13
4.4 External Power	14
4.4.1 Back-up Power or Power Supply for Data Logger	15
4.4.2 Recharge an Internal NiCad Battery Pack	15
4.4.3 Power to all Amplifier Modules	15
4.4.4 Power to the Special Purpose Modules	15
4.4.5 Power to Pwr Terminals	16
4.5 Instrument Power Sources	16
4.5.1 User Power Source	17
4.5.2 +6V unregulated, continuous Micropower	17
4.5.3 FTS External Power circuit	17
4.6 Analog and Digital Ground	18
4.7 High Speed Serial Input/Output Ports	18
4.8 SDI-12 Serial Digital Interface (optional)	20
4.9 Outputs	20

4.10	Available Terminals (48, 49, 50)	20
5.	SIGNAL CONDITIONING OPTIONS	21
5.1	Voltage Dividers and Current Loop References	21
5.1.1	Model 6104A/B/C/D – Voltage Divider	22
5.1.2	Model 6104I/IE and J – Current Loops	23
5.1.3	Model 6507 - Thermistor Temperature Probes	25
5.2	Amplifier Modules and Accessories	26
5.2.1	Model 6105A-DC Amplifier: Single Ended Input	27
5.2.2	Model 6106A - DC Amplifier: Differential Input	28
5.2.3	Model 6107A - Isolated Input Amplifier	29
5.2.4	Model 6110A - Low Level Thermocouple Input Amp.	30
5.2.5	Model 6114A - Single Channel Relay Control Module	31
5.2.6	Model 6117A – Soil Moisture Transducer Interface	32
5.2.7	Model 6141A – Isolated Input Module	33
5.2.8	Model 6142A – Universal Amplifier Module	34
5.3	Special Purpose Modules	38
5.3.1	Model 6140A – Site ID Module	38
5.3.2	Example of Setting the Site ID Number	39
5.4	Sample Circuit	40
5.5	Input Filtering for Counter Inputs	41
6.	INPUT SIGNAL RECORD SHEET	42
 APPENDIX A – Previous Model 6103B		
	PDL Field Termination Strip	A–1
A.	Connections	A–1
B.	Log Start Sense	A–4
C.	Site Identification (I.D.)	A–4
D.	Using Site I.D.	A–4
E.	Disabling Site I.D.	A–5
F.	Site ID Test Program	A–5
G.	Link Descriptions	A–6

1. INTRODUCTION

This supplement explains how to use the STARLOGGER Field Termination Strip (Model 6103D). A Field Termination Strip extends a Data Logger's input signal connections to rows of numbered screw terminals, simplifying on-site installation of a Data Logging System (particularly for complex applications). This Field Termination Strip can be used with:

- Model 6004 STARLOGGERS
- Model 6003 Portable Data Loggers

This supplement also includes a detailed description of how to install the Model 6103C Mounting Frame, and instructions for using signal conditioning modules which can be attached to the Field Termination Strip. These modules are:

- | | |
|---------------|--|
| – Model 6507 | Thermistor Temperature Probes |
| – Model 6105A | DC Amplifier: Single-Ended Input |
| – Model 6106A | DC Amplifier: Differential Input |
| – Model 6107A | Isolated Input Amplifier |
| – Model 6110A | Low Level Thermocouple Input Amplifier |
| – Model 6114A | Single Channel Relay Control Module |
| – Model 6117A | Soil Moisture Interface |
| – Model 6140A | Site ID Module <<NEW>> |
| – Model 6142A | Universal Amplifier Module <<NEW>> |
| – Model 7121A | Isolated Input Module |

Introducing the STARLOGGER Field Termination Strip

The STARLOGGER Field Termination Strip (Model 6103D) was developed to take advantage of the technical advancements offered by the Model 6004 STARLOGGER. New features are:

- More links for signal conditioning and custom configuration
- More terminals for scan synchronised power, continuous Micro power and continuous external power
- Built-in facility to add special purpose modules
- An extra three terminals for custom use
- An Analog Ground is provided for all channels

To accommodate these features, the newly designed board has links on both sides. This version of the Field Termination Strip is compatible with the Model 6103B Strip with two exceptions:

- a) Site ID is now a separate module, not a built-in facility
- b) Counter Terminals are different as described below:

Terminal	Model 6103D	Model 6103B
Terminal 5	Counter 2 (pin 12)	c0u (pin 24)
Terminal 7	Counter 1 (pin 24)	c1/c11 (pin 12)

Other Field Termination Strips

Two other STARLOG Field Termination Strips are available.

Model 7100-1 Macro Field Termination Strip see supplement 6234

Model 6103B PDL Termination Strip see Appendix A

1.1. How to Use This Supplement

This supplement is divided into five chapters and includes one Appendix:

Introduction - which you are reading now, introduces the Field Termination Strip & Frame and describes how information is organised in this supplement.

Installation of Frame and Strip - explains how to install the Mounting Frame and Field Termination Strip.

Terminations - provides a table describing each termination and two diagrams that show where terminations and links are located.

Signal Description - provides specifications for each signal.

Signal Conditioning - describes the signal conditioning options and amplifier modules listed on the previous page.

2. INSTALLATION OF FRAME & STRIP

2.1. Model 6103C - Mounting Frame

This frame is designed to be mounted inside a Model 6701 Weatherproof

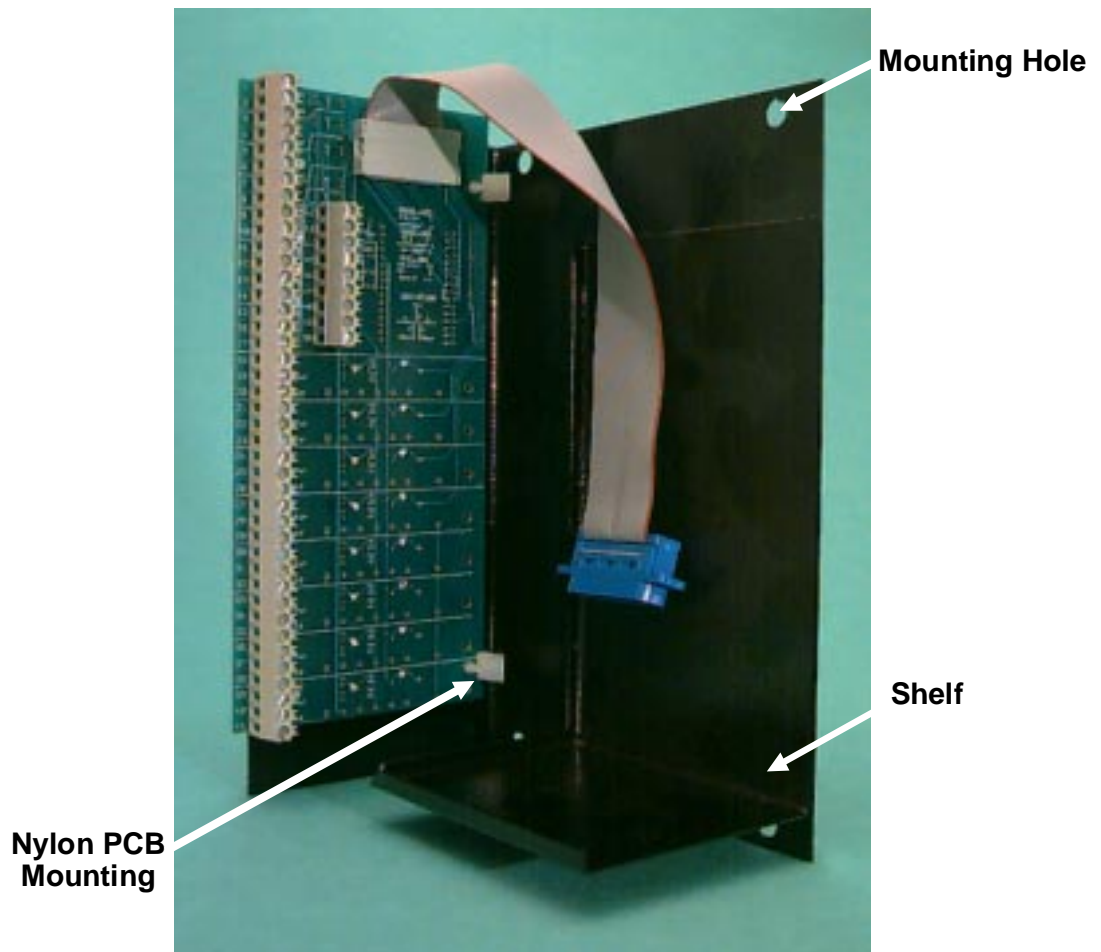

*Model 6103-1 Field Termination Strip
& Mounting Frame*

Enclosure. (The frame may, however, be screwed to any suitable surface).

The frame provides:

- a) a shelf on which the Data Logger is held in place
- b) holes for nylon PCB mountings for the Termination Strip
- c) 4 x 6 mm mounting holes (at each corner)

2.2. Installation of Mounting Frame

The Model 6103B and Model 6103D Termination Strips are designed to be mounted on the Model 6103C Mounting Frame (however the Termination Strip may be mounted in any convenient location adjacent to the Data Logger).

1. Open the Weatherproof Enclosure and locate Mounting Frame inside with the shelf towards the bottom and the angle support to the left side of the enclosure.
2. Use four (4) self tapping screws to secure frame to weatherproof enclosure.

2.3. Installation of Field Termination Strip

The Termination Strip is designed to be mounted on four (4) PCB nylon mountings. The two at the front of the strip are hinged, and the two at the rear of the strip have a retention clip. This mounting arrangement allows the strip to be swung out (forward) from the mounting frame to enable access to the side (for calibration adjustments) and rear (for configuration & soldering) of the installed strip.

1. Firmly push the two rear nylon mounts into the holes provided in the mounting frame. Ensure the retention lever is to the rear.
2. Firmly push the two front mounts into their holes with the hinge edge to the front.
3. Firmly push the two front mounts into the corresponding mounting holes in the front edge of the Termination Strip (so that the Data Logger connection is to the top). Ensure that the small locking tab has passed through the strip and is holding the strip PCB securely.
4. Swing the strip back onto the rear mounts until the retention clip engages. (To release strip, push back the top then bottom retention clip lever and swing the strip forwards).

3. TERMINATIONS

This section provides brief descriptions of terminations and links and two diagrams of the Model 6103D Field Termination Strip.

The table below lists each termination. It includes a brief description, the corresponding channel used in STARLOG Software Version 3, and the corresponding pin in the STARLOGGER Input Signals connector.

Terminal	Description	Channel	Pin
1	Power input for recharging battery and/or operating logger	Battery	16
	PDL: as above and battery output		
2	Digital Ground		23
3	16 bit counter input (3kHz)	C3	25
	PDL: 4 bit counter input (300 Hz)	c1u*	
4	Data Logger power and logic ground		23
5	16 bit counter input (20kHz)	C2	12
	PDL: 4/8-bit counter input (1kHz w/prescale)	c1/c11*	
6	Data Logger power and logic ground		23
7	16 bit counter input (3kHz)	C1	24
	PDL: 4-bit counter input (300Hz)	c0u*	
8	Data Logger power and logic ground		23
9	16 bit counter input (20kHz)	C0	11
	PDL: 4/8-bit counter input w/prescale (1kHz)	c01 / c0*	
10	Data Logger power and logic ground		23
11	High Speed Synchronous Serial Port Data 0 (TTL level Input/Output)	s0 to s7	21
	PDL: as above, but Input only		
12	High Speed Synchronous Serial Port Clock 0 Buffered output signal		9
13	High Speed Synchronous Serial Port Clock 1 (TTL level Output)		22
	PDL: Clock 1 unbuffered output signal only		
14	Data Logger power and logic ground		23

Table continued on next page...

Terminal	Description	Channel	Pin
15	+5V, 250mA Scan Synchronised User Power Source		13
16			
17			
18	ANALOG 7 +ve signal Input	A7	8
19	ANALOG 7 -ve signal Input or Power		
20	Ground		23, 14
21	ANALOG 6 +ve	A6	7
22	ANALOG 6 -ve or Power		
23	Ground		23, 14
24	ANALOG 5 +ve	A5	6
25	ANALOG 5 -ve or Power		
26	Ground		23, 14
27	ANALOG 4 +ve	A4	5
28	ANALOG 4 -ve or Power		
29	Ground		23, 14
30	ANALOG 3 +ve	A3	4
31	ANALOG 3 -ve or Power		
32	Ground		23, 14
33	ANALOG 2 +ve	A2	3
34	ANALOG 2 -ve or Power		
35	Ground		23, 14
36	ANALOG 1 +ve	A1	2
37	ANALOG 1 -ve or Power		
38	Ground		23, 14
39	ANALOG 0 +ve	A0	1
40	ANALOG 0 -ve or Power	A0	
41	Ground		23, 14
42	Control, Open Collector output, 30V max., 100mA drive, 5 μ s – 250ms pulse width	Out 0	17
43	+6V continuous power for external instruments (1mA maximum)	Micropwr	18
	PDL: not available		
44	Sense 1/SDI-12 (CMOS) input	Sense 1	20
45	SERIAL channels 8 to 14, input & output	s8 – s14	10
46	Analog Ground		14
47	CMOS output, HSIO Sync/5 μ s–250ms pulse	Out 1	15

Table continued on next page...

Terminal	Description	Channel	Pin
48	Available		
49			
50			

3.1. Special Purpose Modules

Hole	Description
1	Clock 0
2	Data 0
3	Sense 1/SDI-12
4	Data 0 (Terminal 11) via link x
5	Micropower
6	Out 0
7	External power (Terminal 1) via link b(ext)
8	Out 1/HSIO Sync
9	5Vp (scan synchronised 5V pulse from logger)
10	Digital Ground
11	Analog Ground
12	Counter 0 (C0) (Terminal 9)
13	Counter 0 (C0) via Link b(C0)
14	multipurpose (Terminal 48) via link f (see External Power)
15	Terminal 49 via link u
16	Terminal 50 via link v

3.2. Links

Link	Description
LS	Sense 0 (Log Start, pin 19) connected to Ground
a	Pull up to +5Vp
b	Divider Series Resistor
c	Pull down to Digital Ground
d	Pull down to Analog Ground

e	Ax-/Pwr to +5Vp
f	Ax ground to Digital Ground
g	Ax ground to Analog Ground
k	Ax+ terminal to Ax input of Logger
m	Ax-/Pwr to -ve input of amplifier module
n	Ax-/Pwr to Micro power
p	Ax-/Pwr to External Power Circuit
r	Ext. Power Term. to amp. modules & Ax-/Pwr Terms. via Link p
s	S.P.M. hole 14 to amp. modules & Ax-/Pwr terminals via Link p
t	Terminal 48 to S.P.M. hole 14 or Link s
u	Terminal 49 to S.P.M. hole 15 or Link s
v	Terminal 50 to S.P.M. hole 16 or Link s
w	Data 0 Terminal to Data 0 pin of Logger
x	Data 0 Terminal to S.P.M. hole 4

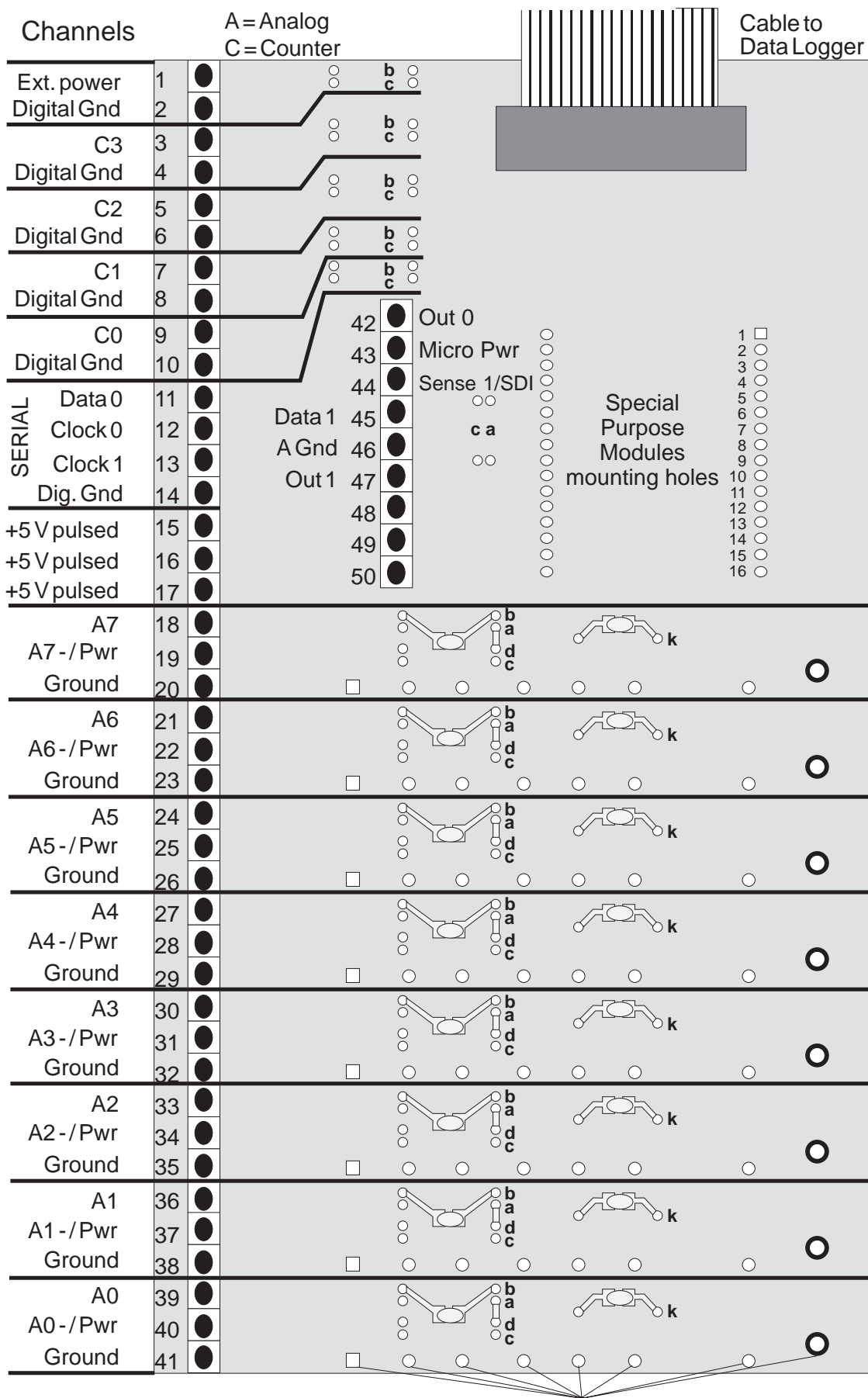

Amplifier module mounting holes
Model 6103D Field Termination Strip (front side)

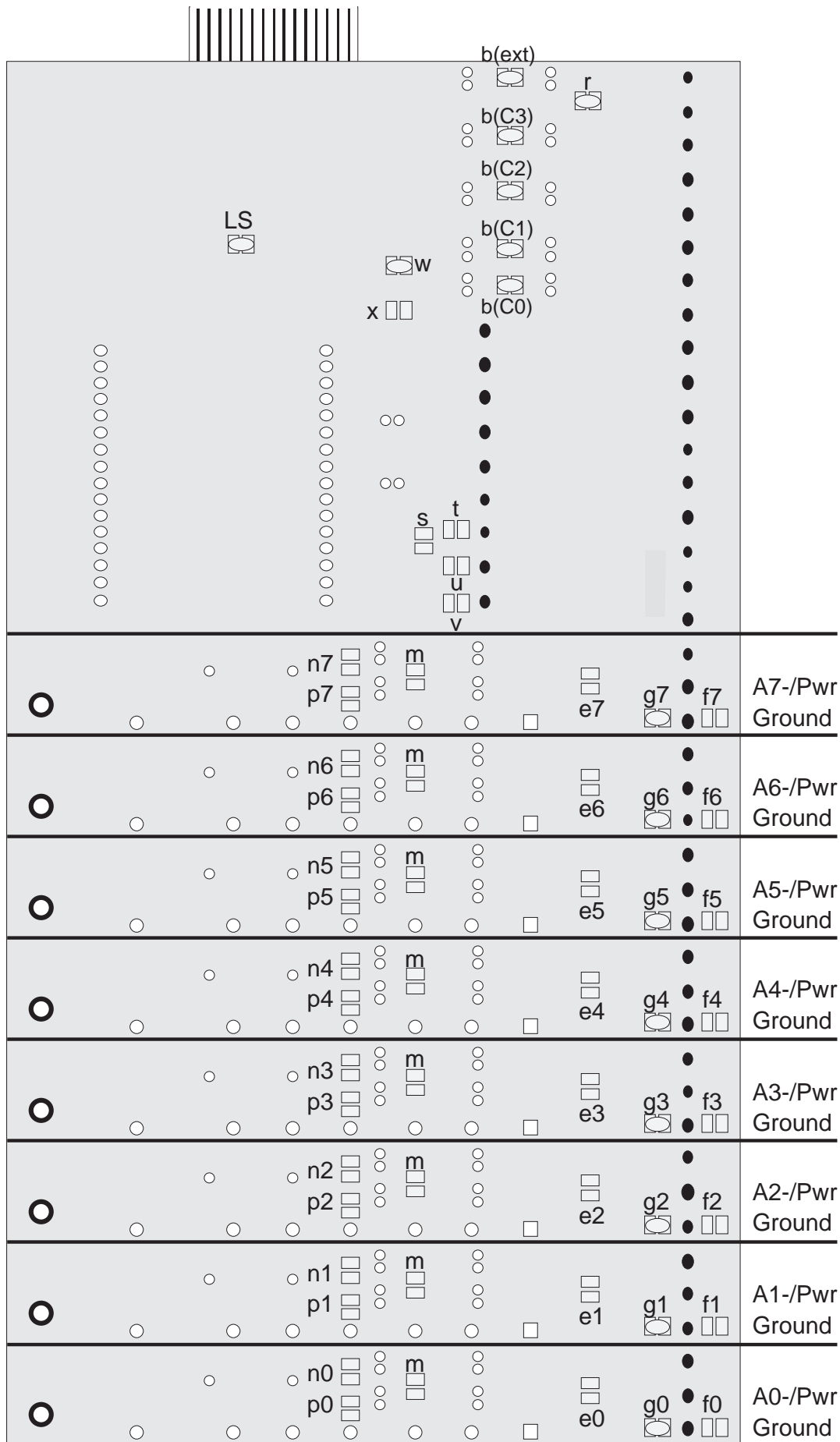

Model 6103D Field Termination Strip (links on back)

4. SIGNAL DESCRIPTION

The STARLOGGER accepts many different kinds of signal. The Field Termination Strip offers terminals for each input and output. In addition, using links on the Field Termination board, most terminals can be customised offering an even wider range of possible inputs and outputs. This section describes each signal possible using the Field Termination Strip, its links and terminals.

If you are using this Strip with a Portable Data Logger, some features described below are not available to you – refer to the Appendix.

4.1. Log Start Sense (Link LS)

Normally, the Data Logger only begins to record when an instrument is connected to the INPUT SIGNALS. To sense this condition, there is a Link (LS) on the back of the Field Termination Strip which connects Pin 19 (Log Start Sense 0) to ground. It is normally connected so that when the FTS is plugged into the Logger, Sense 0 is connected to ground. This causes the Logger to begin

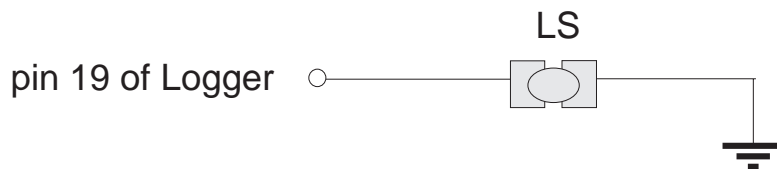

operating.

4.2. Analog Inputs

Terminals labelled A0 – A7 can be logged as low resolution values (8 bit data) or high resolution values (10 bit data). Their usage depends on how you refer to the input using STARLOG software. The software interprets analog inputs as low resolution channels when you refer to them as a0 – a7 and high resolution channels when you refer to them as A0 – A7 (or, h0 – h7 in Version 2 Software).

The Ax-/Pwr Terminal can be used as a negative input (via **Link m**) if a module is installed on the FTS which requires this. See diagram section 4.5.

All Analog channels are programmable to carry a signal in one of two ranges: 0 to 2.550 V (2.5 mV per bit) and 0 to 255 mV (250 μ V per bit). Input impedance (when the logger is active) is greater than 1 M Ω . Load impedance (when the Logger is inactive) for signals less than 500 mV is greater than 1 M Ω , while for

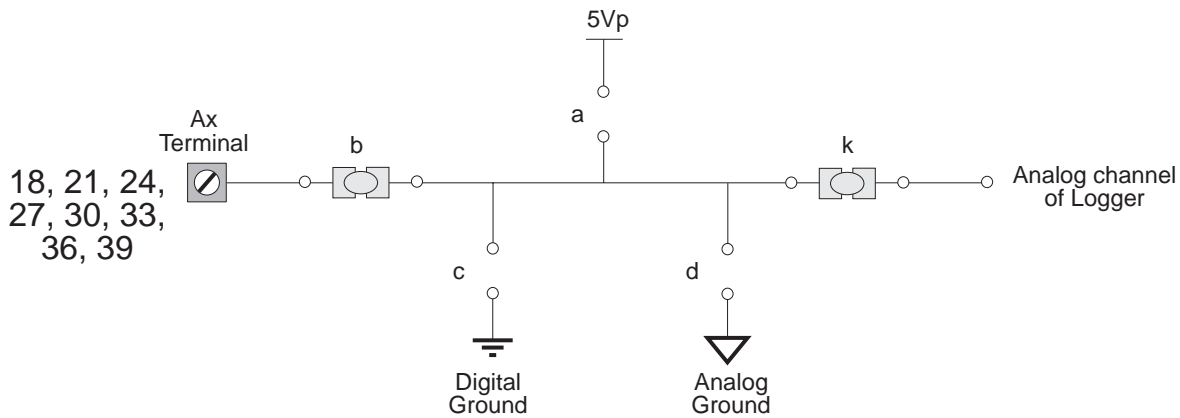

S

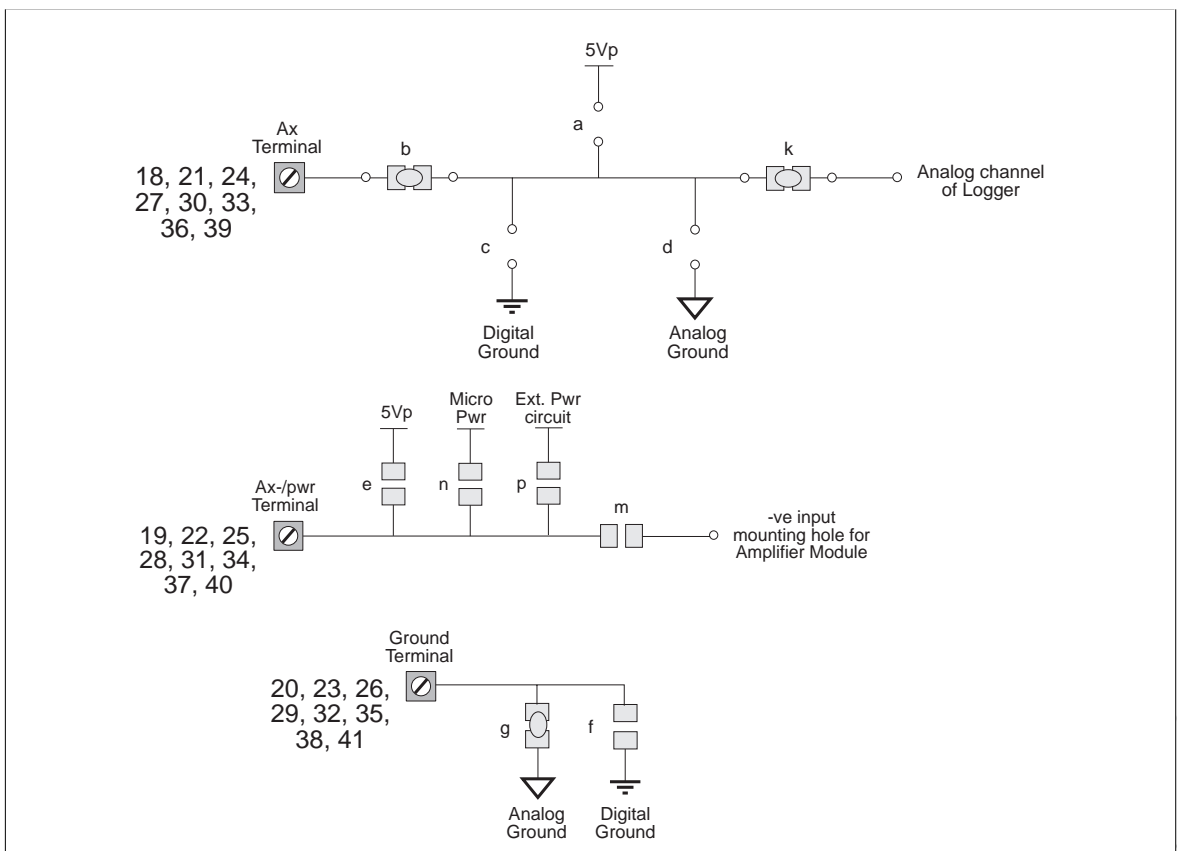

i
g
n
a
l

s greater than 500 mV, it is 10 kΩ. The recommended source drive impedance is <10 kΩ.

Analog signals can be conditioned using the following links on the FTS.

Pull-up to +5V

Link a

Used to install thermistor reference resistors or to convert an analog channel for ON/OFF sensing.

Divider Series Resistor

Link b

Used as part of a voltage divider network (for example, with Model 6104A/B/C/D Voltage Resistors.) Can also be used for a series resistor. Or a filter resistor on counter channels.

Pulldown to Digital Ground

Link c

Used to install a filter capacitor (for pulse inputs) or voltage divider resistor (for voltage attenuation).

Pulldown to Analog Ground

Link d

Protection Series Resistor

Link k or Link b

Used to install a resistor in series with the input signal (to prevent excessive external power being applied to the logger.)
Used for externally powered signals (e.g., voltages, active pulses).

Direct Input

Link k

Installed to connect the Data Logger channels to their associated terminals when an Amplifier Module is not being used to pre-condition the input signal. The 'k' link is removed when an Amplifier Module is fitted.

Isolated Input

Link m

Installed to connect the Analog -ve signal input to the associated Amplifier Module. The link is installed for Differential or Isolated input signals being connected to differential or isolated amplifier modules. The link is otherwise not installed.

WARNING: Ensure that Links e, n and p are not installed. Do not use Link m if these links are installed. Damage may occur to the amplifier module or an instrument connected to an Ax-/Pwr terminal.

4.3. Counters

Counters are CMOS inputs, suitable for 20 kHz potential free contacts, open collector outputs or 0–5V to 0–12V DC digital signals.

Maximum pulse rate to C0 & C2 is 20 kHz, and to C1 & C3 is 3 kHz. Pulse

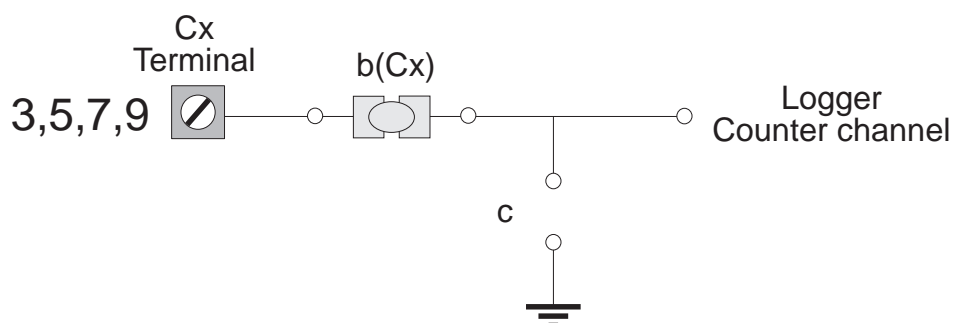
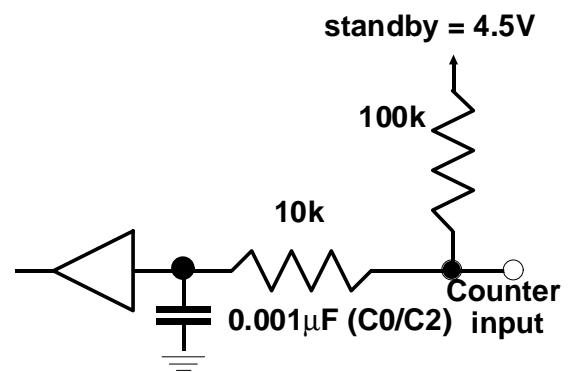

rates must also be related to scan rate, to ensure counters do not overflow before being scanned by the Logger.

Links **b** and **c** can be used if attenuation or extra filtering is required.

4.4. External Power

There are several ways to use External Power via the Field Termination Strip. The external power may be used with an Alkaline or NiCad battery pack as a backup power source or simply on its own. (A mains power pack and a solar recharge module are available from UNIDATA.)

The External Power circuit has been designed so that more than one external power source can be used at the same time. Power can be made available to the Logger, several Terminals (labelled Ax/Pwr), the amplifier modules, and special purpose modules. Uses of an External Power Source are:

- Back-up Power or Power Supply for a Logger
- Recharge a Logger's internal NiCad battery pack
- Provide power to all ext pwr* amplifier mounting holes
- Provide power to Pwr Terminals
- Provide power to/from Special Purpose Modules (7 & 14)
- Provide power to Available Terminal 48

IMPORTANT

The supply voltage to the Data Logger must be maintained at all times to ensure correct logger operation and data integrity.

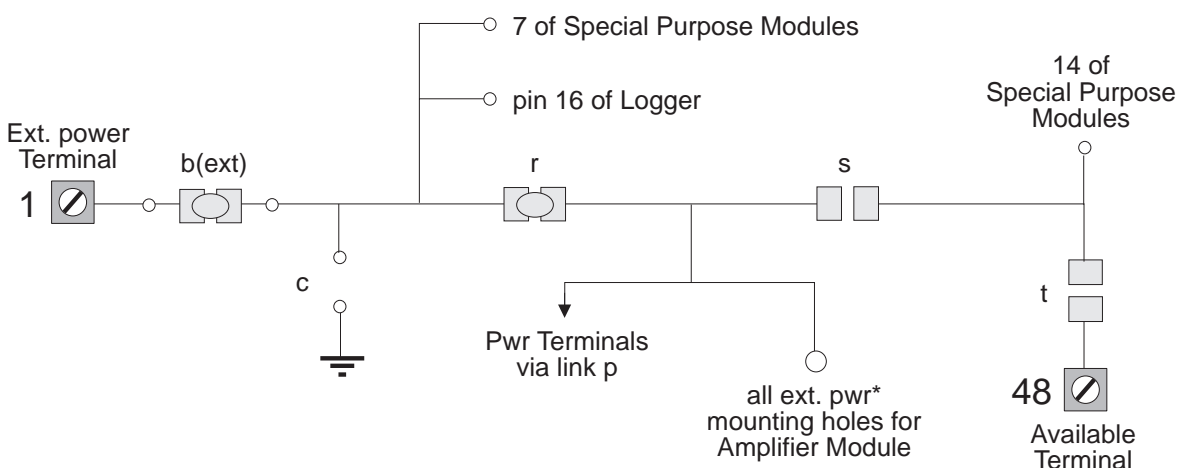

Voltage to the logger must be in the range of 9V to 20V and able to supply a load of 100mA peak (increasing to 500mA when recharging a battery).

The diagram below shows the External Power circuit. See section 4.5 to learn how External Power can be used via Pwr Terminals.

The following sections describe these different uses of External Power.

To install an External Power Supply:

1. Connect +ve to Ext. Power Terminal 1 or Available Terminal 48.
2. Connect -ve to Terminal 2 (or any other Digital Ground).
3. Check that Links are installed or removed depending on how the installation is using the power (see sections below.)

4.4.1. Back-up Power or Power Supply for Data Logger

Power is supplied from Ext. Power Terminal 1 to STARLOGGER pin 16 when **Link b(ext)** is installed. **Link c** can be used with a zener diode to regulate the voltage.

4.4.2. Recharge an Internal NiCad Battery Pack

The Data Logger with a NiCad battery pack can be recharged from a solar recharge panel or a mains power pack or other DC power source. The input voltage should be between 11V and 20V.

- » NOTE: NiCad Battery Packs require several charge/discharge cycles before their full charge is retained. Therefore, ensure the Data Logger has been fully charged (connected to solar recharge or mains power pack) then left to discharge at a fast rate.

Connect recharge power source as described above, in section 4.4.1.

4.4.3. Power to all Amplifier Modules

Power is supplied from Ext. Power Terminal 1 to the ext. pwr* hole of **all** amplifier modules when **Link b(ext)** and **Link r** are installed. **Link c** can be used to regulate the power source. Alternatively, power is supplied from Terminal 48 when **Link t** and **Link s** are installed.

Special Purpose Modules can also be used to provide power to the ext. pwr* hole of **all** amplifier modules from 14 (via **Link s**).

4.4.4. Power to the Special Purpose Modules

External Power can be supplied to hole 7 of the Special Purpose Modules. Power is supplied from Ext. Power Terminal 1 to hole 7 when **Link b(ext)** is installed.

4.4.5. Power to Pwr Terminals

Power is supplied to the Pwr Terminals from Ext. Power Terminal 1 when **Links b(ext), r** and **p** are installed. Alternatively, power is supplied from Available Terminal 48 to the Pwr Terminals when **Links t** and **s** and **p** are installed or from Special Purpose Module hole 14 via **Links s** and **p**.

4.5. Instrument Power Sources

There are several options for providing power via the Field Termination Strip to instruments in a data logging system. The following connections can be used to provide power:

Instrument Power Sources	Connections
Pwr Terminals (UPS, Micropower or Ext. Power)	19, 22, 25, 28, 31, 34, 37, 40
User Power Source (UPS) +5V regulated, scan synchronised	15, 16, 17
Micropower +6V unregulated, continuous	43

Each type of power source is available from an Ax-/Pwr Terminal using links.

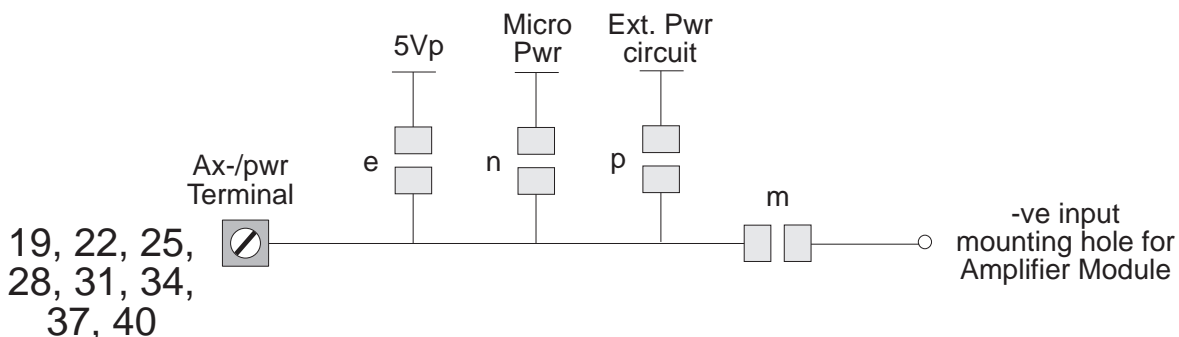

WARNING:

Only one link (e, n, p or m) can be safely installed for each channel, otherwise damage may result. UNIDATA recommends that you remove any unused links.

4.5.1. User Power Source

The User Power Source (+5V regulated, scan synchronised) is intended to power instruments associated with the Data Logger. The full load output capability is 250mA in pulsed mode.

The UPS switches on and off (synchronised with the logger scan). Any loads connected to these outputs will contribute to the drain on the Data Logger battery (and reduce battery life).

The UPS may be programmed to switch on prior to the logger scan by setting the Prescan in the STARLOGGER Configuration Table. (See the STARLOGGER supplement 6244 and the User's Manual.)

The User Power Source is immediately available through Terminals 15, 16 and 17 and via hole 9 of the Special Purpose Modules. It is also available through the Ax-/Pwr Terminals via **Link e**.

4.5.2. +6V unregulated, continuous Micropower

The Micropower source provides +6V unregulated, continuous power for external instruments. The full load output capability is 1mA.

Micropower is immediately available through Terminal 43 and via hole 5 of the Special Purpose Modules. It is also available through the Ax-/Pwr Terminals via **Link n**.

4.5.3. FTS External Power circuit

External power is available to instruments through the Ax-/Pwr Terminals via **Link p** and via hole 14 of the Special Purpose Modules (using **Link b(ext)** as shown in section 4.4).

4.6. Analog and Digital Ground

Terminals labelled Ground can be used as Analog or Digital Grounds depending on which links are installed (see diagram).

Digital Grounds are also available through six Terminals labelled Digital Gnd, the square Amplifier Module mounting holes (hole 1) and hole 10 of the Special Purpose Modules.

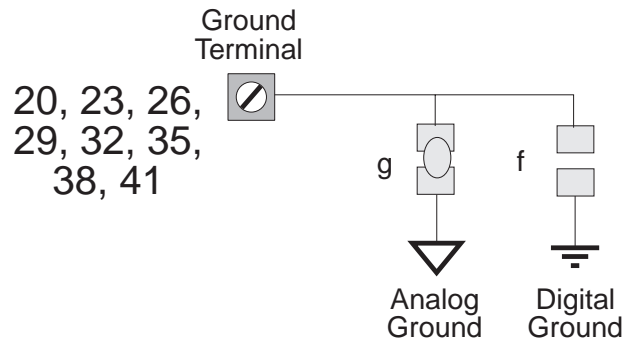

Analog Ground is also available through Terminal (46), the second Amplifier Module mounting holes (hole 2) and hole 11 of the Special Purpose Modules.

4.7. High Speed Serial Input/Output Ports

There are two serial ports:

Port 0	Terminal 11 (Data 0) Terminal 12 (Clock 0)	s0 - s7
Port 1	Terminal 45 (Data 1) Terminal 13 (Clock 1) Terminal 15, 16 or 17	s8 - s14 +5V sync signal

The Data 0 Terminal can also be linked (via **Link x**) to hole 4 of the Special Purpose Modules.

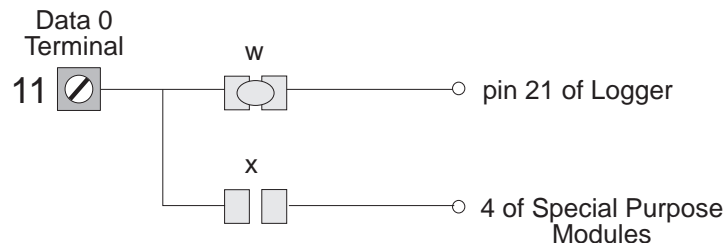

Each logger scan, the High Speed Serial Ports are read. Any of the +5V power supplies (Terminals 15, 16, 17) may be used as a "Sync signal" to indicate to remote equipment that a logger read scan is about to begin. This signal is usually used to load the serial shift register(s) in the remote equipment in preparation of being read.

» NOTE: the first data bit LSB must be present on the Data (0/1) input within 7ms after the Sync signal.

Serial transfer rate is 50 microseconds per bit with a 30 microsecond gap between each byte (timing diagrams on next page).

- » NOTE: every 1 millisecond a logger interrupt sequence adds a 50 microsecond delay to the serial transfer sequence. Transfer starts with the least significant bit of the least significant byte and each clock reads the next most significant bit.

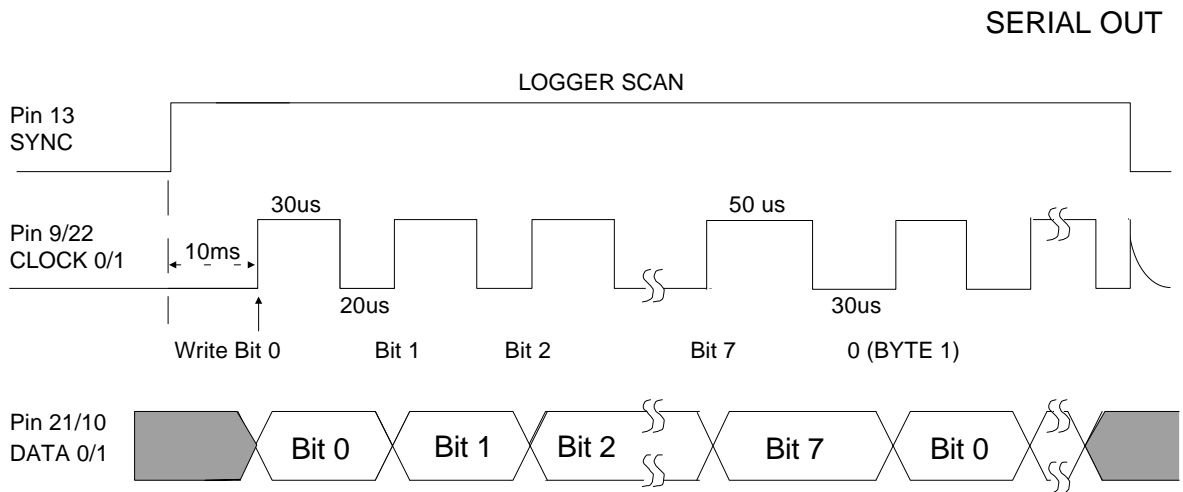
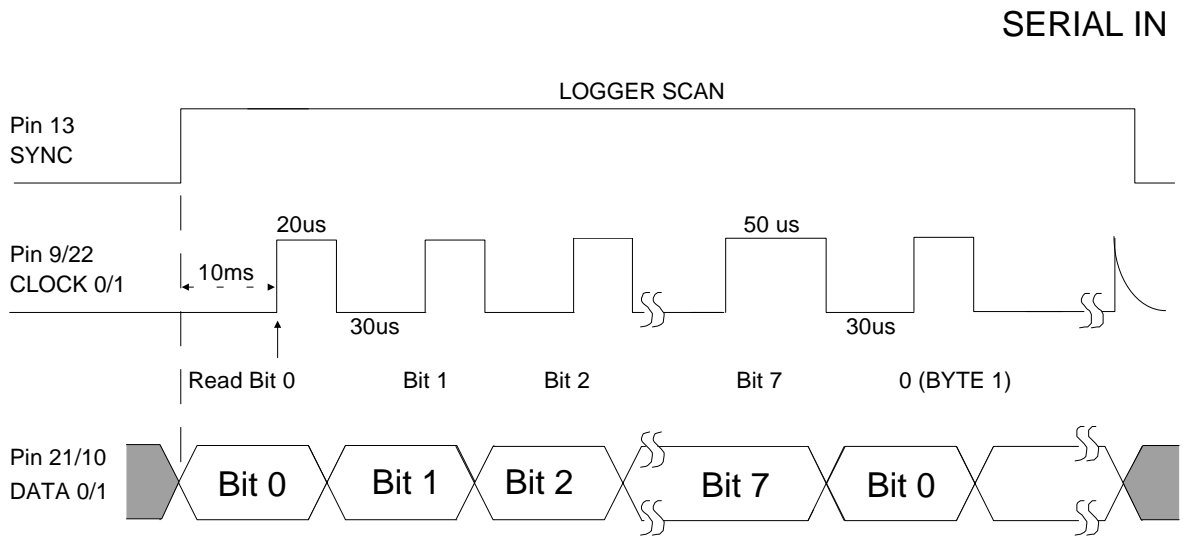

4.8. SDI-12 Serial Digital Interface (optional)

The STARLOGGERS support the U.S. SDI-12 standard for serial data interchange between the logger and intelligent instruments.

SDI-12 is implemented as an alternate use of Sense 1 (Terminal 44). Up to ten SDI-12 compatible instruments may be connected onto this bus. Programming the SDI-12 interface is supported in Version 3 STARLOG Software.

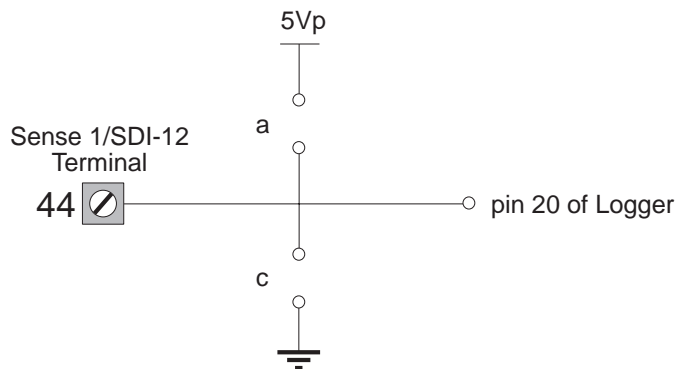

See the STARLOGGER supplement 6244 for details on how to use the SDI-12 Interface.

4.9. Outputs

There are two outputs:

- Out 0 Open Collector Output Terminal 42
- Out 1 CMOS Output Terminal 47

The Open Collector Output (Out 0) is rated at 100mA and can be used to switch on/off relays controlling experiments.

4.10. Available Terminals (48, 49, 50)

Three terminals are available for use via the Special Purpose Modules.

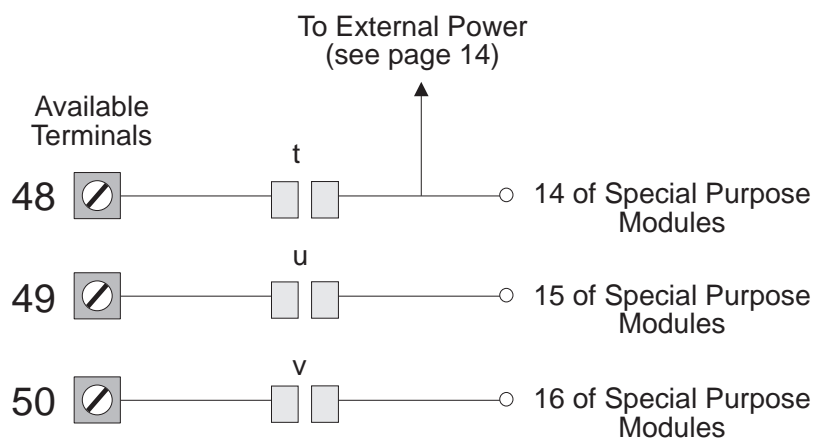

5. SIGNAL CONDITIONING OPTIONS

The Field Termination Strip offers convenient facilities to mount signal conditioning and amplifier modules. The mounting holes designations are shown below.

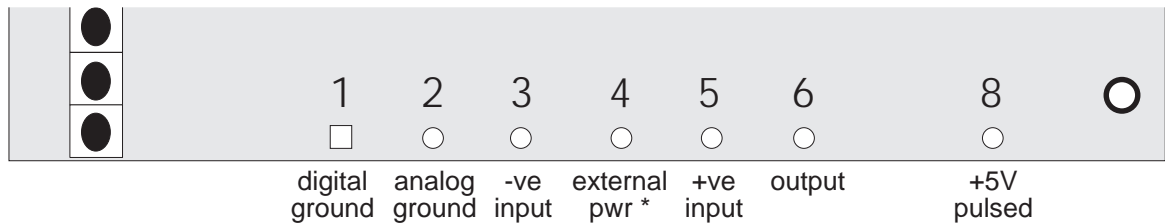

(See page 9 for their locations on the printed circuit board.)

In addition to the links described in the previous section, the following input signal conditioning modules are available for all Analog channels.

5.1. Voltage Dividers and Current Loop References

When you use one of these options in a STARLOG Data Logging Scheme you will want to ensure that the voltage divider (or current loop reference) is wired in properly on the FTS and that you have added it to the Scheme using STARLOG Software.

To add the option to a Scheme (using Version 3 Software):

1. Open the **Scheme Editor**.
2. Select the **Instruments** menu, then **Add an Instrument**.
3. From the List of Instruments, select the signal conditioning option you have chosen.
4. Finally, you will want to calculate the Scaling Formula and enter it in the **Transducer** menu.

The following sections explain how to wire voltage dividers and current loop references to the Field Termination Strip.

5.1.1. Model 6104A/B/C/D – Voltage Divider

1. Remove solder blob connection from **Link b**(see page 9).
2. Insert 100k Ω resistor in **Link b**.
3. Insert a second resistor in **Link c**.
4. Do not remove **Link k**.

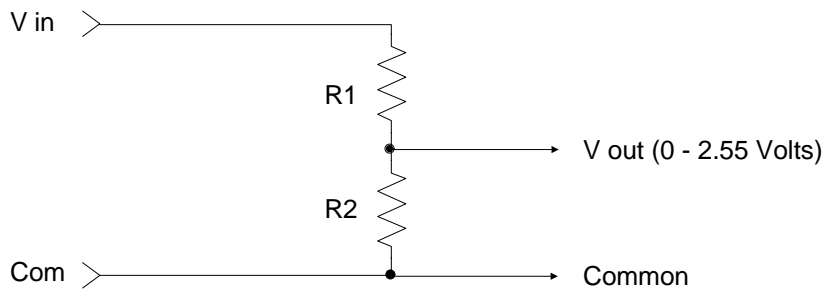

The formula for calculating voltage divider resistors is:

$$(V \text{ in}) / (V \text{ out}) = (R1+R2) / R2$$

» Note – Resistor R1 should be larger than 47k (100k suggested).

5.1.2. Model 6104I/E and J – Current Loops

1. Fit one of the following loop reference resistors to **Link c**.

Model 6104I	100 Ω for 4–20mA
Model 6104I/E	120 Ω for 4–20mA
Model 6104J	250 Ω for 0–10mA

2. Leave **Links b** and **k** connected.

3. Use Analog +ve and Common as signal inputs.

Using Model 6104I Logger will read 000 at 0mA, 40 at 4mA,
200 at 20mA and 255 at 25.5mA.

Using Model 6104I /E Logger will read 000 at 0mA, 48 at 4mA,
and 240 at 20mA

Using Model 6104J Logger will read 100 at 4mA, 250 at 10mA.

Up to eight current loops can be measured by the STARLOGGER. To use more than one current loop device, we recommend that you use an Isolated Input Module (Model 7121A) fitted with a Model 6104I, J or I/E to isolate the device from the logger and to avoid errors caused by ground loops. If you do not use this module please ensure that it is permissible to common all current loop grounds at the Data Logger end.

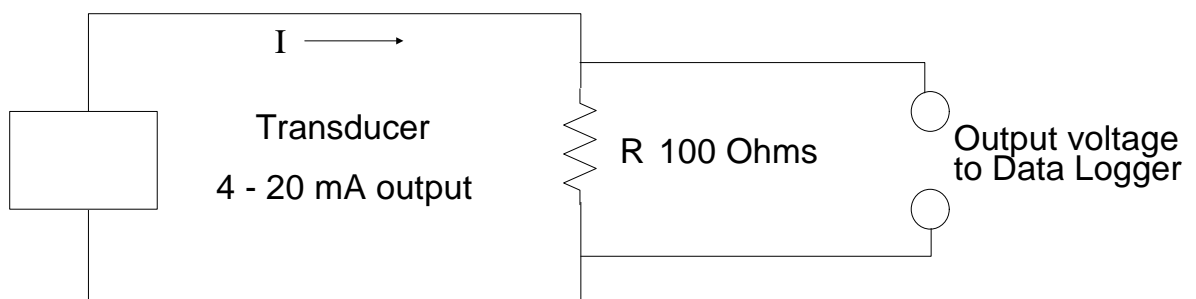

Model 6104I Current Loop Reference

To record information from a current loop device you need to determine the equivalent zero and full scale values of the transducer.

1. Determine the input signal range corresponding to the 4 – 20 mA output range. This will be found in the specifications of the device.

eg, level 4 – 20 mA corresponds to 0 – 100 metres

the 0 is the **transducer min input**

the 100 is the **transducer max input**

the difference between the two is the **transducer input range**

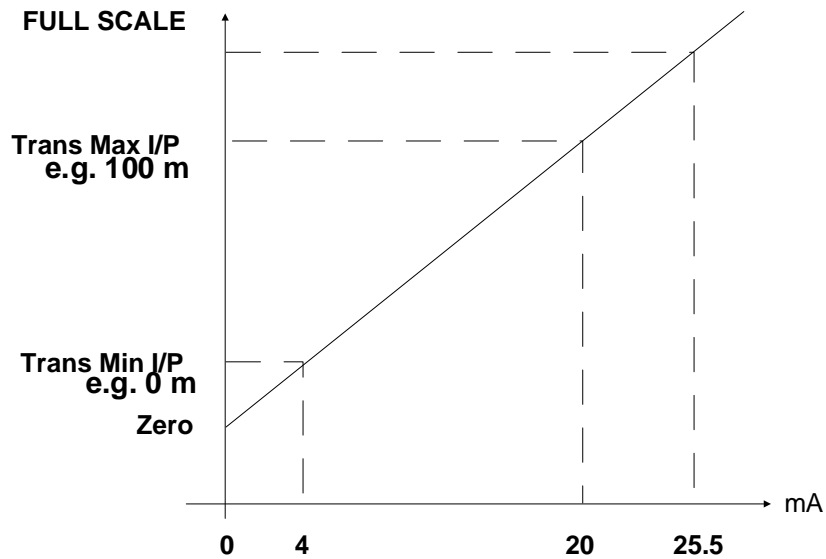

2. Calculate corresponding logger readings. I.e., multiply the reference resistor value by the current loop reading.

e.g. $4 \text{ (mA)} \times 100 \text{ } (\Omega) = 400\text{mV}$
 $20 \text{ (mA)} \times 100 \text{ } (\Omega) = 2000\text{mV}$

Your transducer range is 400 to 2000. Scaling formula is 0 to 100.

These values would now be used to scale the transducer (in the **Transducer** window using the STARLOG Software Version 3).

5.1.3. Model 6507 - Thermistor Temperature Probes

1. Fit **Link k** (factory fitted)
2. Fit thermistor reference (usually, 15k Ω resistor) to **Link a**.
3. Connect thermistor cable to Analog +ve and Digital Ground (polarity doesn't matter).

5.2. Amplifier Modules and Accessories

Small signals may be measured by the Data Logger by using a signal amplifier. These low power instrumentation amplifiers consist of a small circuit board module which mounts perpendicular to the Field Termination Strip (FTS) adjacent to the eight Analog input terminations.

To install the amplifier modules:

1. Remove the appropriate **Link k**.
2. Position module adjacent to the Analog channel to be conditioned with component side to the top of the FTS.
3. Feed the module leads through the corresponding holes in the Termination Strip.
4. Secure the module with an M2.5 x 6mm screw & nut to the FTS (if module is fitted with bracket).
5. Solder the module pins to the strip (from the back) and trim off excess leads.

Zero & gain adjustments

1. Set gain to maximum.
 2. Then set zero. zero is normally set with the minimum (lowest) signal to be measured. (Data Logger should read 0 or 1.)
 3. Then set full scale. Full scale is set with the maximum (highest) signal to be measured (Logger should read 254 or 255.)
- » Note: Calibration is done using **Scheme Test Mode** of STARLOG Software to read the Data Logger's memory locations.

5.2.1. Model 6105A-DC Amplifier: Single Ended Input

1. Remove **Link k**.
2. Install module (see next page).
3. Connect Data Logger and set zero & gain adjustments for desired signal range. The following procedure should be used:
 - 1) Use **Scheme Test Mode** to look at the channel's memory location.
 - 2) Feed an input of 100mV to 1.0 V into i/p.
 - 3) Check the reading on the computer.
 - 4) Adjust zero and gain to read:
0V at 0V input and 2.55V at full-scale.
4. Use Analog +ve and Digital Ground as signal inputs.

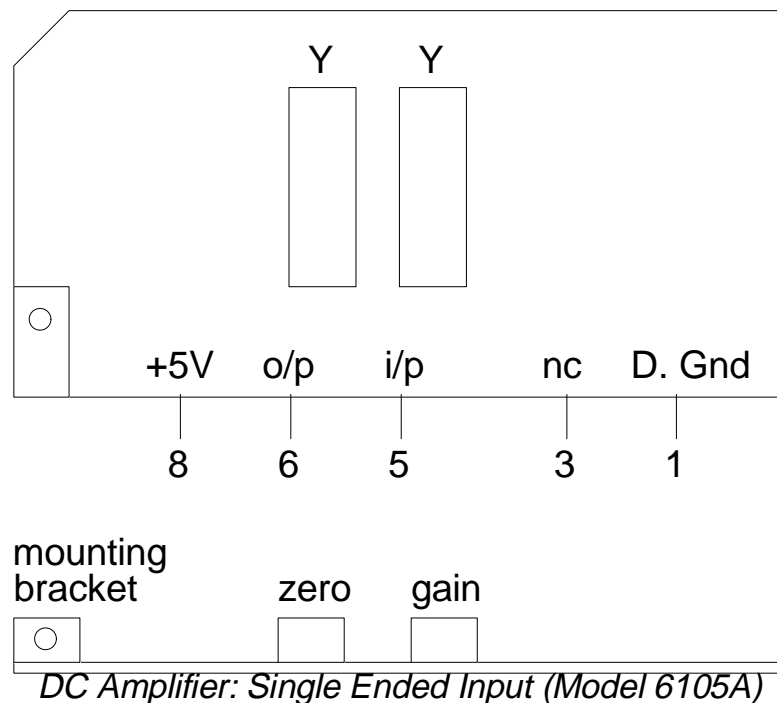

5.2.2. Model 6106A - DC Amplifier: Differential Input

1. Remove **Link k**.
2. Install **Link m**.

**WARNING: Ensure that Links e, n and p are not installed.
Damage may result if they are.**

3. Install module (see below).
4. Connect Data Logger and set zero & gain adjustments for desired signal range.
5. Use Analog +ve and Analog -ve as signal inputs.

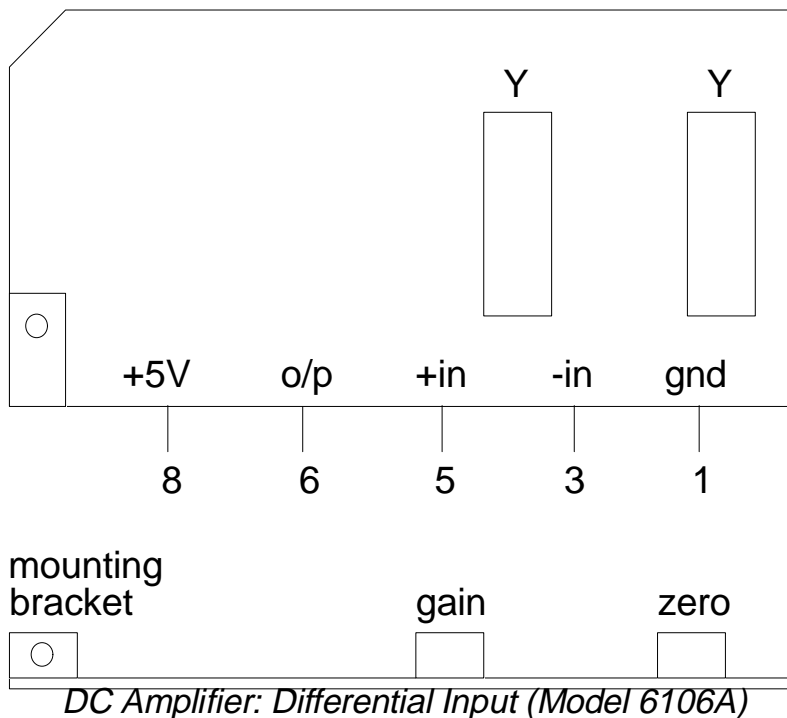

5.2.3. Model 6107A - Isolated Input Amplifier

1. Remove **Link k**.
2. Install **Link m**.

**WARNING: Ensure that Links e, n and p are not installed.
Damage may result if they are.**

3. Install module (see below).
4. Use Analog +ve and Analog -ve as signal inputs.
5. Connect Data Logger and set zero & gain adjustments for desired signal range.
6. Zero will adjust to a reading of 0, 1 or 2 bits.
7. Gain will adjust from unity (*1) to (*100). Zero adjust will become more sensitive as gain is increased. Recommended input voltage is around 100 millivolts full-scale.
8. For bipolar inputs (+ and - voltage/current) set the zero adjustment to read half scale (127). Input values will then be either side of this.
9. Power consumption of logging system will increase by approx. 10% for each isolation module fitted.

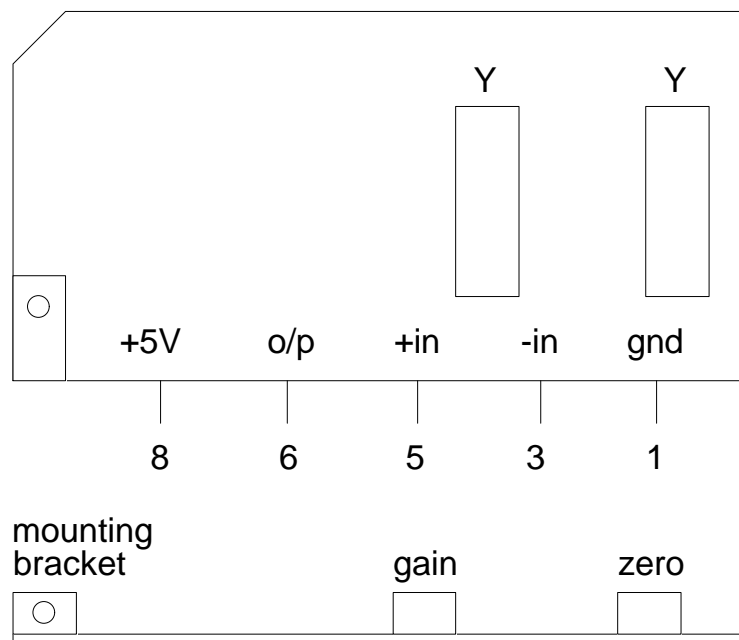

Isolated Input Amplifier (Model 6107A)

5.2.4. Model 6110A - Low Level Thermocouple Input Amplifier

If Field Termination Strip Terminals are being used, rather than the module's T3/T4, install **Link m**.

WARNING: Ensure that Links e, n and p are not installed. Damage may result if they are.

1. Remove **Link k**.
2. Install module (see below).
3. Connect the thermocouple, Chromel to Analog +ve, Alumel to Analog -ve.
4. If optimum cold junction compensation is required use terminals provided on module (T3=Chromel, T4=Alumel).
5. Module has no adjustments.
6. Scaling of signal to logger is 0 to 255°C.

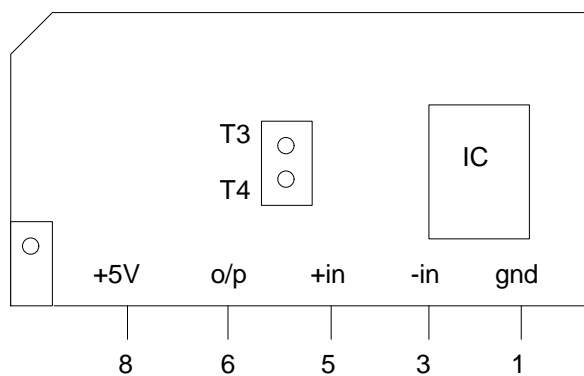

*Low Level Thermocouple Input Amplifier
(Model 6110A)*

» Note - this unit is only designed for type "K" thermocouples.

5.2.5. Model 6114A - Single Channel Relay Control Module

To use this Module you will want to define a Scheme which uses an event to send a Pulse Output to Output 1. (See the STARLOG Users Manual.)

1. Remove **Link k**.
2. Install **Link m**.

**WARNING: Ensure that Links e, n and p are not installed.
Damage may result if they are.**

3. Mount module.
4. Connect the top (upper) lead (OUT 0) to Terminal 42 (open collector output.).

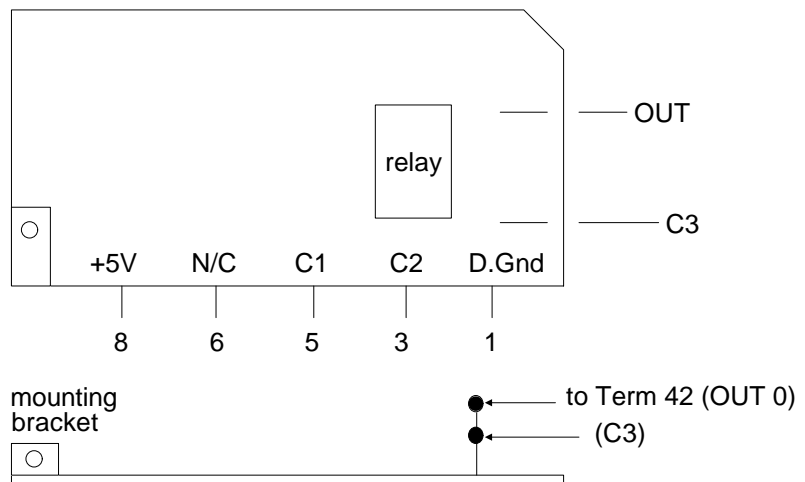

Single Channel Relay Control Module (Model 6114A)

The C1/C2 relay contacts are now connected to the Ax+ and Ax-/pwr terminals. To monitor the status of the C1/C2 relay contacts, you should use the channel to monitor C3. The analog channel will now read close to zero when C1 and C2 are shorted and will read full scale when C1 and C2 are open.

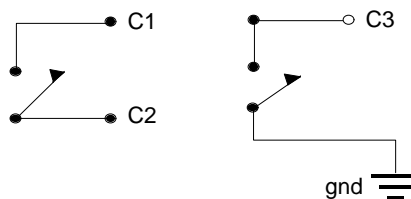

The relay will be "toggled" with each pulse sent to it by the Logger. This is done by a PULSE #x instruction.

It is possible to have signal conditioning (voltage divider) and the Analog +ve and Analog -ve screw terminals free (for the channel which would be occupied by the 6114A Module) by connecting the 5V and GND wire but not connecting the C1 and C2 relay wires. These can be replaced with wire, or better, with terminals. **Link k** should not be removed and **Link m** not installed in this case.

5.2.6. Model 6117A – Soil Moisture Transducer Interface

1. Remove **Link k**.
2. Install **Link m**. This connects the negative signal input to the interface module.

WARNING: Ensure that Links e, n and p are not installed. Damage may result if they are.

3. A 10k Ω reference resistor is fitted to the interface between the 5V Logger supply and the output signal. This is the default reference and may be replaced with either 5, 15 or 20k Ω resistors.
4. Solder the interface module to the FTS on the required channel and tighten the support nut/bolt.
5. Screw the Soil Moisture Block leads into the positive and negative input terminals (of the chosen channel).
N.B. Not positive and ground terminals.

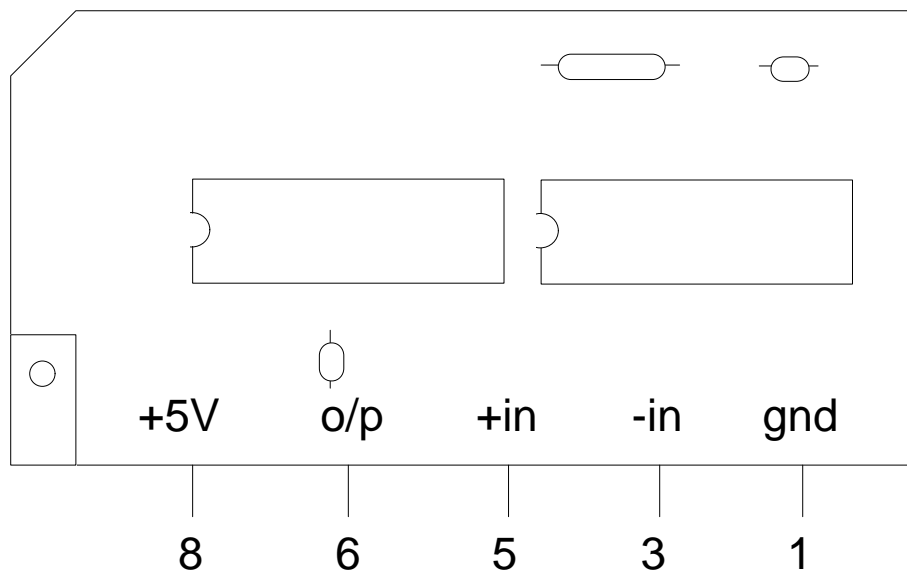

Model 6117A – Soil Moisture Transducer Interface

5.2.7. Model 6141A – Isolated Input Module

The Isolated Input Module provides isolation for transducers which cannot be directly connected to the Logger, e.g., current loop transducers powered from separate supplies. Eight modules can be fitted onto the Field Termination Strip.

1. Remove **Link k** .
2. Install **Link m** .
3. Check that **Links n, p and e** are not installed.
4. Solder Module to FTS on desired analog channel – it will only fit one way (see diagram.)
5. Connect input signal to A and A-/Pwr terminals on the FTS.

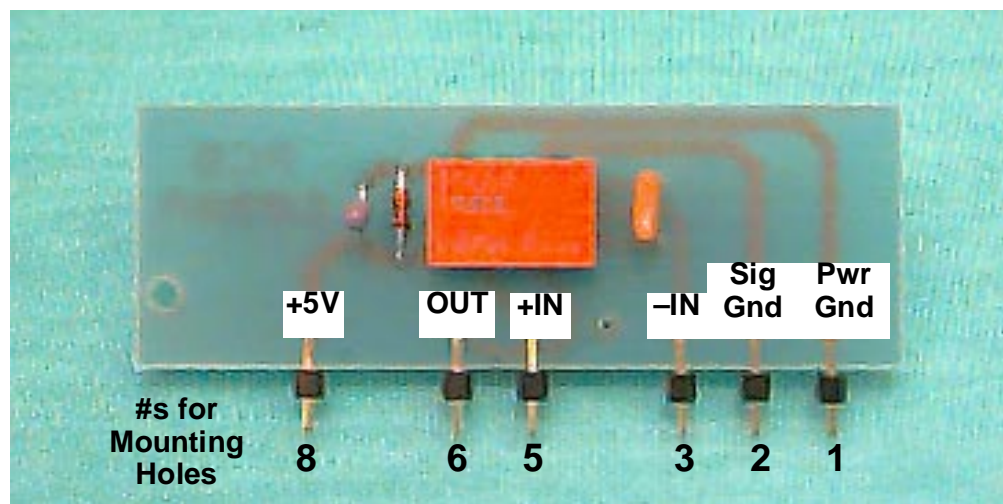

Model 6141A – Isolated Input Module

Specifications:

- Input Signal: single-ended or differential, 0 to ± 2.55 V DC
- Output Signal: isolated input signal, not amplified
- Isolation: flying capacitor, relay isolated
- Power: 5V DC, 25mA from Logger

5.2.8. Model 6142 – Universal Amplifier Module

This is a multi-range amplifier module for use with Model 6004 STARLOGGERS. It is soldered directly onto the Model 6103D Field Termination Strip adjacent to a selected analog input channel.

The amplifier extends the STARLOGGER signal range allowing the connection of:

- Thermocouples
- Strain Gauges
- PT-100 bridges
- Thermopiles (pyronometers, radiometers)

➤ Gain Setting

A DIL switch provides six precision gain settings:

SW# ON	Input Signal Range		Gain Factor	Logger Resolution
	Unipolar	Bipolar		
all OFF	2.5 V	+1.25 V to –500 mV	1	2.5 mV
1	1.0 V	±500 mV	2.5	1.0 V
2	500 mV	±250 mV	5	500 µV
3	250 mV	±125 mV	10	250 µV
4	100 mV	±50 mV	25	100 µV
5	50 mV	±25 mV	50	50 µV
6	10 mV	±5 mV	250	10 µV
7	Adjustable (see below)			
8 ON 8 OFF	ON for single ended signals OFF for differential signals			

* Only one selection switch should be ON.

➤ Adjustable Gain (SW7 ON)

This allows you to customise the amplifier module with your own gain setting. You need to fit two fixed resistors (R7 and R8) calculated so their total resistance (sum) is:

$$\text{Resistance (R7 + R8)} = \frac{49.4\text{Kohms}}{(\text{GAIN}-1)}$$

Alternatively, you may substitute a multi-turn trimmer resistor for R8 which then allows you to adjust the amplifier gain to any setting from 1 to 1,000.

Resistors R7 and R8 are to be soldered into spare locations immediately below SW7 and SW8. The trimmer resistor if used instead of R8 is soldered into the spare location next to the DIL switch.

➤ Fitting the Amplifier to Field Termination Strip

To fit the amplifier to the Field Termination Strip:

1. Solder closed Links **b** and **m**. All other links should be open.
(Note: in the factory setting, Links **b** and **k** are closed.)
2. Solder module onto the FTS. (It only fits one way.)

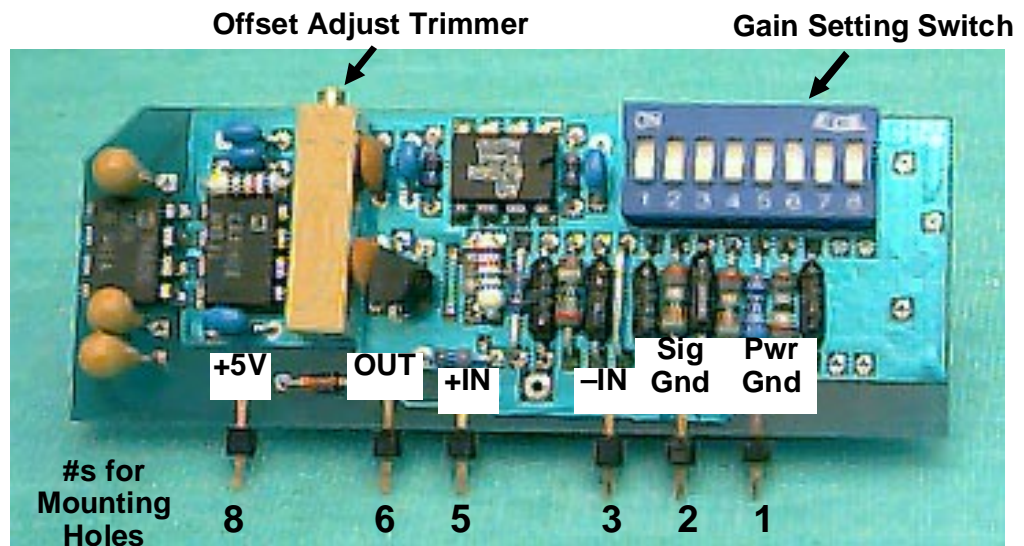

Model 6142A Universal Amplifier Module

➤ Input Signal Connections

The amplifier accepts single-ended and differential input signals which may be unipolar or bipolar. Signal inputs are connected into two of three terminals available for the chosen analog channel:

Input Signal	Description	Analog Terminals
Differential Unipolar or Bipolar	+ve signal -ve signal	A A-/Pwr
Single Ended Unipolar or Bipolar	+ve signal -ve signal	A Ground
Inverting Single Ended Unipolar or Bipolar	+ve signal -ve signal	A-/Pwr Ground

Unipolar Signals – The amplifier is factory set to accept unipolar signals and no further adjustment is necessary.

Bipolar Signals – The amplifier Offset Adjust Trimmer must be set to read zero volts output for the most negative input signal to be used. To adjust the Bipolar offset:

1. Select desired Gain setting (see page 33).
2. Apply the most –ve input signal and adjust Offset Trimmer anti-clockwise until you have a reading on that channel (using **Test Mode**.)
3. Carefully adjust (clockwise) until reading just changes to zero.

➤ Software Scaling

To ensure your logged data is reported correctly in reports and graphs, you need to enter the correct scaling factors for the instrument being connected. Use the Add an Instrument facility in the software package and calculate scaling by the following method:

from a to b scaling

It is necessary to determine two points (**a** and **b**) of measurement.

Point a (lower point)

Set the instrument to measure near the lowest used value and record that value and the corresponding logger reading in mV. (Note: a is usually chosen to be 0mV.)

For example,

i) Pressure Sensor	0kPa=	0mV	a
	50 kPa =	1990mV	b
ii) pH Probe	7pH =	500mV	a
	9.5pH =	1080mV	b

Point b (upper point)

Set the instrument to measure near to its maximum used value and record that value and the corresponding logger reading in mV.

Enter these two pairs of readings into the instrument's scaling definition:

5.3. Special Purpose Modules

The Field Termination Strip offers two banks of 16 holes for mounting Special Purpose Modules. (See diagram page 10 and table pages 7 & 8.)

5.3.1. Model 6140A – Site ID Module

The Site ID Module is a Special Purpose Module that enables you to assign a number used to identify a logging site. There are two switches and two jumpers on the module which determine what the Site ID number is. Part of a switch is used to determine whether or not the Site ID option is being used.

To install the Module:

1. Install **Link x**.
2. Remove **Link w**.
3. Set Jumpers on the back of the module for either an 8 bit or 14 bit number.

	8 bit Mode	14 bit mode
JP1	removed	installed
JP2	installed	removed
Uses	SW1 only	SW1 & SW2(1–6 only)

4. Install Module in one of the Special Purpose mounting positions (as shown in diagram).
5. Set the Site ID number use SW1 and SW2 levers 1–6.
6. Enable Site ID by setting SW2 levers 7–off and 8–on.

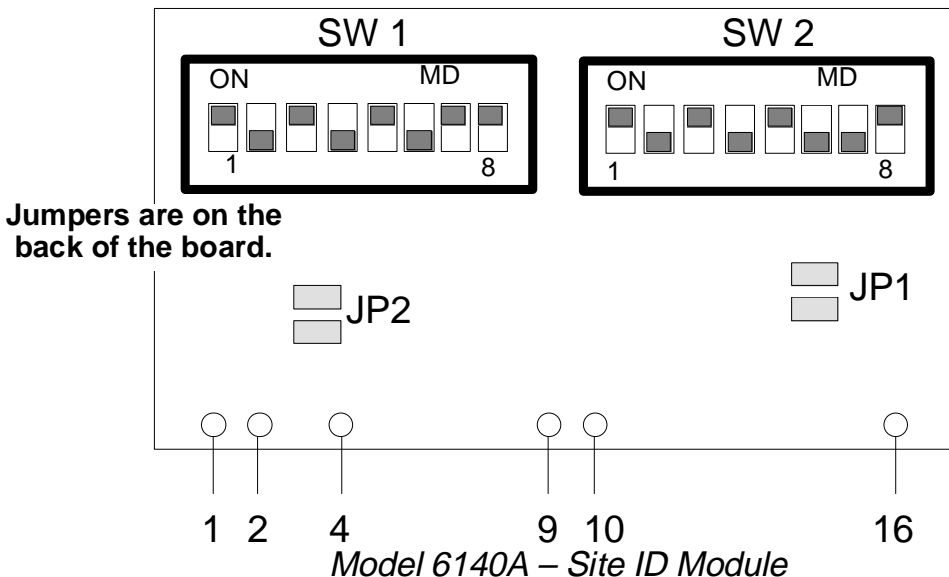

Each switch lever in the 8-way DIL switches is labelled with a number from 1 to 8. All but two of these switch levers set the Site ID number. Switch levers 7 and 8 on SW2 are used to enable and disable the Site ID option.

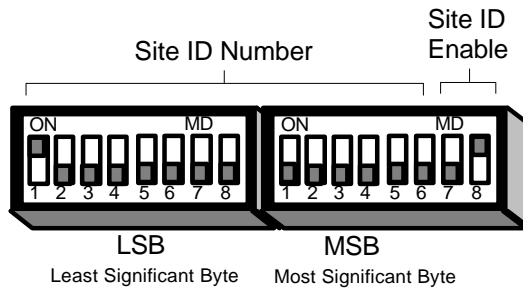

The settings to enable and disable Site ID are shown to the right.

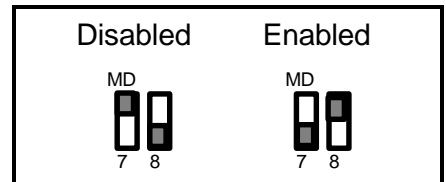

The Site ID number is set by the combination of settings on the first 14 switch levers (see diagram above, LSB switches 1 to 8 and MSB switches 1 to 6).

Each switch lever represents a number as shown in the picture on the right. These numbers are binary values - each switch lever is a power of 2 in ascending order. When a switch lever is set to the ON position its value is added to the Site ID number.

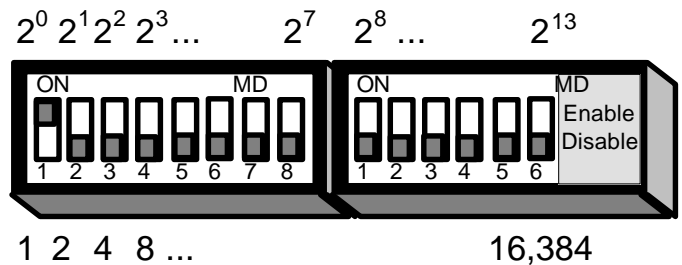

For example, switch lever 1 on the first switch (LSB) adds 1 to the Site ID number, switch lever 3 adds 4 to the Site ID number. (See the example below.)

5.3.2. Example of Setting the Site ID Number

This picture illustrates how to set the site ID number to 645. Four switch levers are set to ON.

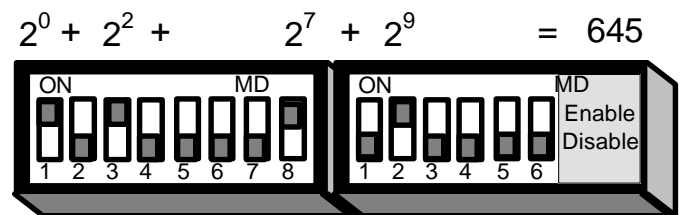

First Switch (LSB)	Switch 1	$(2^0) = 1$
	Switch 3	$(2^2) = 4$
	Switch 8	$(2^7) = 128$
Second Switch (MSB)	Switch 2	$(2^9) = 512$

The Site ID number is 645

5.4. Sample Circuit

This example details a simple monitoring project requiring to measure the voltage and current in a solar recharge system. The voltage (nominally 12 volts) is connected to channel Analog 1 which is fitted with a 10:1 voltage divider so that the logger reading 000 means 0 volts and 255 is 25.5 volts.

The solar power (in or out) is measured by a current shunt which develops 100 millivolts for a current of 10 amps. The shunt input is connected to channel Analog 0 which is fitted with an isolated amplifier module to provide ground free reference to the shunt voltage (100mV FSD) and amplification. It may be desired to adjust the amplifier zero so that zero current flow reads 127 on the logger. This will allow current flow into and out of the battery to be measured.

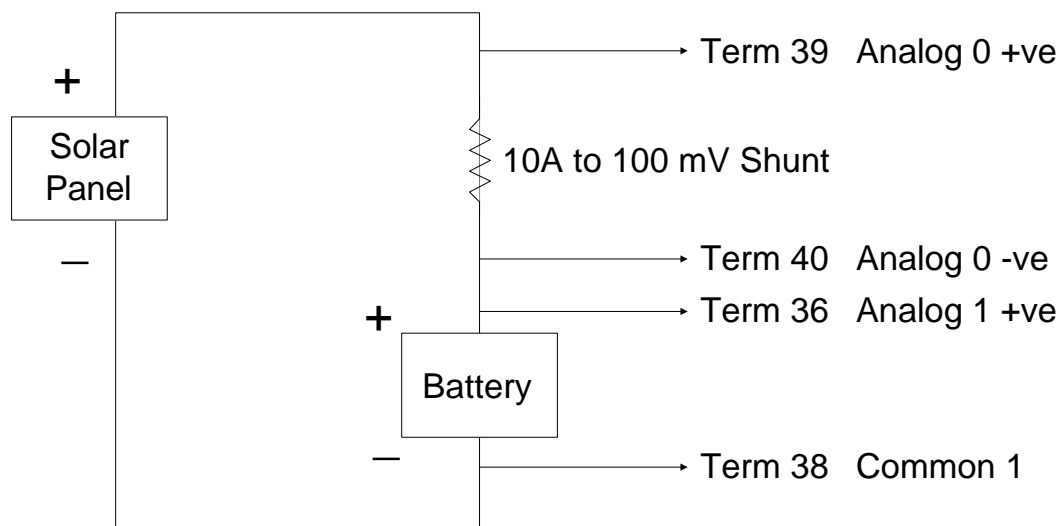

Solar Recharge Monitoring - Example

5.5. Input Filtering for Counter Inputs

All counter inputs have filtering to remove noise and unwanted signals. For certain types of input (normally relay contacts) the internal filtering may not be sufficient. A slowly actuating relay contact may have sufficient “contact bounce” to produce large errors usually in the form of a much larger number of pulses recorded than were actually applied. This problem can be solved by using an external filter circuit. The form of external filter used will vary depending upon the maximum pulse rate to be recorded and the severity of the bounce problem but would typically take the form of a capacitor across the contacts with a series resistor as shown in the diagram.

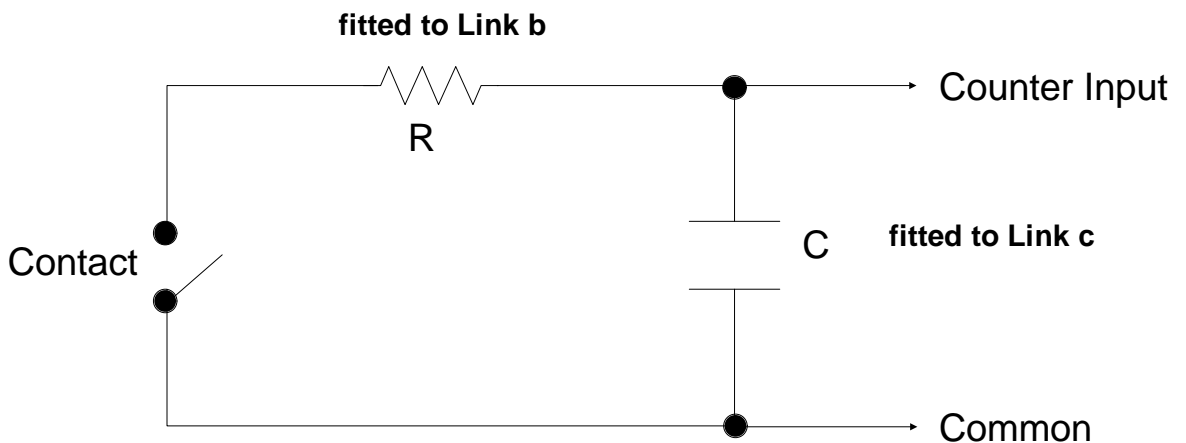

The value of C would typically vary from 0.01 microFarads to 1 microF depending upon the application. The resistor R may not be required for small values of C and robust contact types but would typically be: 100 Ω to 1k Ω .

6. INPUT SIGNAL RECORD SHEET

Channel	Description	Scaling from/to	Units	Links/ Modules
A0				
A1				
A2				
A3				
A4				
A5				
A6				
A7				
C0				
C1				
C2				
C3				
Data 0				
Data 1				
Out 0				
Out 1				
Sense 1				

APPENDIX A

Previous Model 6103B PDL Field Termination Strip

The Portable Data Logger Field Termination Strip is the earlier version of the STARLOGGER Field Termination Strip which is described in detail in the body of this supplement. In most cases, the operation of the PDL FTS is the same as the STARLOGGER FTS. However, the board layout is different and some of the features of the STARLOGGER FTS are different or not available on the PDL FTS. For instance, Site ID is a switch on the PDL FTS, not a module as described for the STARLOGGER FTS.

This appendix provides a table and diagram of connections on the PDL FTS. It also includes signal descriptions (for users of the Portable Data Logger) and details on how to use the following signal conditioning options (which are not necessary for the STARLOGGER FTS):

- Model 6108A – AC Voltage Input
- Model 6109A – AC Current Input
- Model 6109B – 5V DC Power Supply

A.1. CONNECTIONS

The table below lists each termination. It includes a brief description, the corresponding channel used in STARLOG Software Version 3, and the corresponding pin in the Portable Data Logger Input Signals connector.

Terminal	Description	Channel	Pin
1	Voltage test (must be over 6.5V) or power input for recharging NiCad Pack	Battery	16
2	Data Logger signal and logic ground		23
3	4-bit counter input (300 Hz) - C1 upper	C1U	25
4	Data Logger signal and logic ground		23
5	4-bit counter input (300 Hz) - C0 upper	C0U	24
6	Data Logger signal and logic ground		23
7	4/8-bit counter input w/prescale (1kHz)	(C1L) C1	12
8	Data Logger signal and logic ground		23
9	4/8-bit counter input w/prescale (1kHz)	(C0L) C0	11
10	Data Logger signal and logic ground		23

Terminal	Description	Channel	Pin
11	SERIAL channels 0 to 7, input only (TTL)	S0 to S7	21
12	CLOCK 0 (TTL Input/Output)		9
13	CLOCK 1 (TTL Input/Output)		22
14	Data Logger signal and logic ground		23
15	+5V, 50mA regulated power for devices		13
16	+5V, 50mA regulated power for devices		13
17	+5V, 50mA regulated power for devices		13
18	ANALOG 7 +ve signal Input	A7	8
19	ANALOG 7 -ve signal Input	A7	
20	ANALOG 7 Common	A7	23
21	ANALOG 6 +ve	A6	7
22	ANALOG 6 -ve		
23	ANALOG 6 Common		23
24	ANALOG 5 +ve	A5	6
25	ANALOG 5 -ve		
26	ANALOG 5 Common		23
27	ANALOG 4 +ve	A4	5
28	ANALOG 4 -ve		
29	ANALOG 4 Common		23
30	ANALOG 3 +ve	A3	4
31	ANALOG 3 -ve		
32	ANALOG 3 Common		23
33	ANALOG 2 +ve	A2	3
34	ANALOG 2 -ve		
35	ANALOG 2 Common		23
36	ANALOG 1 +ve	A1	2
37	ANALOG 1 -ve		
38	ANALOG 1 Common		23
39	ANALOG 0 - +ve	A0	1
40	ANALOG 0 - -ve		
41	ANALOG 0 Common		23
42	Control, Open Collector output, 30V, 100mA drive, 20ms pulse width	Output 1	17
43	No Connection	reserved	18
44	Sense 1, (CMOS) input		20
45	SERIAL channels 8 to 14, input & output	S8 - S14	10

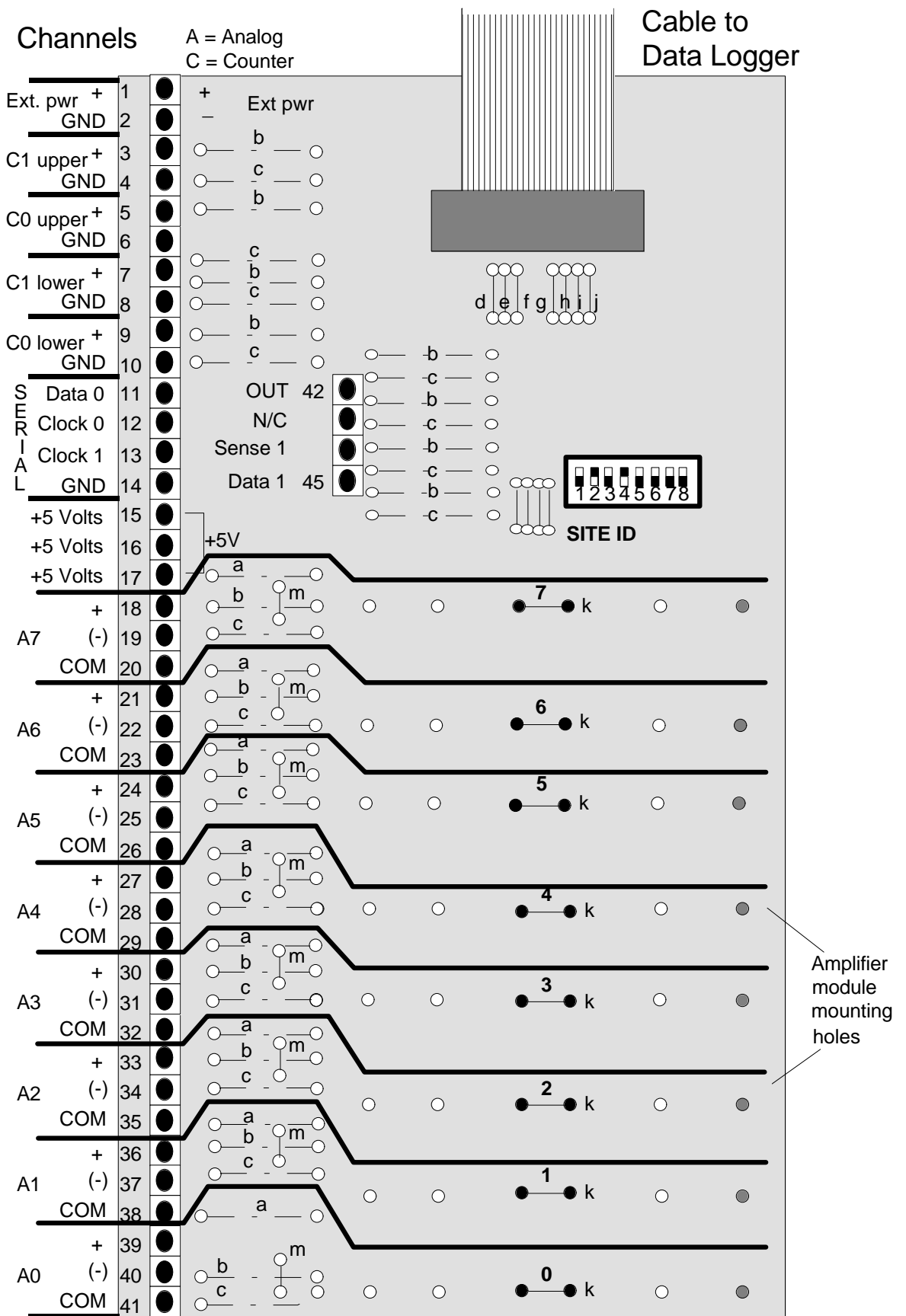

ABBREVIATIONS USED FOR LINKS

a	Pull-up to +5V	e	N.C.	Term 43	i	Clock 0	Term 12
b	Series Resistor	f	Digital 1	Term 44	j	Clock1	Term 13
c	Pull-down to GND	g	Data 1	Term 45	k	Direct Input Link	
d	Output 1 Term 42	h	Data 0	Term 11	m	Amplifier Link	

Terminal	Description	Channel	Pin
**	Sense 0 (Log Start) connected to GND		19

A.2. LOG START SENSE

The 'Log Start' Sense is a link track on the board which is normally fitted so that when the FTS is connected to the Logger, pin 19 is connected to ground. This enables the Logger to recognise when you connect the FTS to the Input Signals connector and then start the Logger scan.

A.3. SITE IDENTIFICATION (I.D.)

To identify a site from which data was collected users may designate an 8-bit code for each site using a Field Termination Strip (FTS). This code is set by a switch located on the FTS and is recorded in the Data Logger memory.

An 8 position DIL switch labelled "SITE I.D" is fitted to the FTS for Site ID.

A.4. USING SITE I.D.

If you are using Version 2 Software and a Field Termination Strip with the Site ID, you will want to indicate this in the scheme definition. The Site I.D. is automatically read into Address 254 and generates the required software in the Logger program.

1. In the **Hardware Details** section select **Fitted** in the **Site Identification** menu
2. In the **Output Details** section, add the following to the title of a report or plot for Schemes using Portable Data Loggers:

[val(b254)]

E.g. ,

Report Title **Climate Station Number [val(b254)]**

The resulting title printed will include the Logger Site ID. Eg, for site #3:

Climate Station Number 3

3. For a Scheme using a MACRO Data Logger, the Site ID requires two bytes, so, the title of a plot or report must include:

[val(w254)]

Note: If you wish to restore Site ID after you have disabled it (by following the steps below), simply reverse the disable procedure and change the scheme definition in software. You will lose the first byte of serial data if you do not restore Site ID hardware.

A.5. DISABLING SITE I.D.

To disable Site ID, ensure that the scheme definition does not include Site ID, and:

1. Solder 1 link and cut 1 track on the back of the FTS.

NOTE: Unless this link is soldered across, the Site ID will always be read in ahead of all serial input data, regardless of whether or not Site ID is enabled in software.

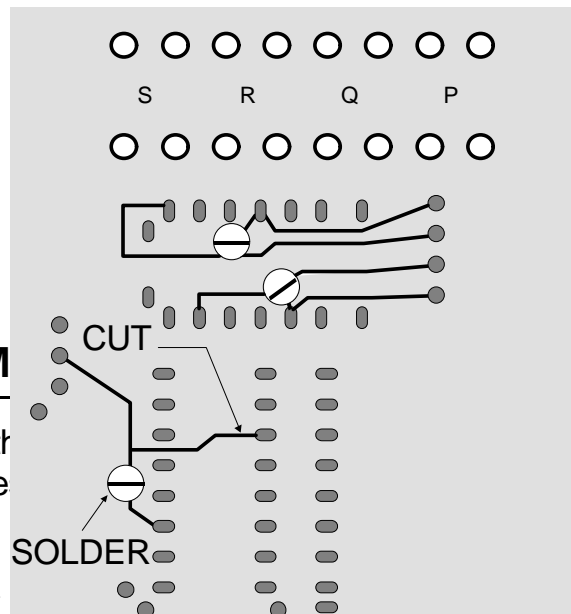

A.6. SITE I.D. TEST PROGRAM

The following logger program will store the **Logger** in Version 2 software to Put (pre the following values in these Addresses.

Address 384	72
Address 385	1
Address 386	100
Address 387	0
Address 388	0
Address 8	0
Address 9	128
Address 10	64

A.7. LINK DESCRIPTIONS

Link 'a' Pull-up to +5V

... for each Analog channel. This component location is used to install thermistor reference resistors or to convert an analog channel for ON/OFF sensing.

Link 'b' Series Resistor

... for all channels. This component location is used to install a resistor in series with the input signal (to prevent excessive external power being applied to the logger). Used for voltage divider networks and any externally powered signals (e.g. active pulses, voltages). When a link 'b' resistor is fitted, the corresponding 'LINK - TRACK' on the reverse side of the Termination Strip must be cut (1mm gap) using a sharp knife.

Link 'b' Divider Series Resistor

Link 'b' component is also used as part of a resistor voltage divider network (along with Link 'c'). In this mode, the Link 'k' is used as a series resistor to prevent external power being applied to the logger.

Link 'c' Pulldown to GND

This component location is used to install a filter capacitor (for pulse inputs) or voltage divider resistor (for voltage attenuation). For all channels.

Links 'd' to 'j'

Insert links to connect the appropriate Data Logger signals to their associated terminals.

Link	Logger Pin	Terminal
d	17	42
e	18	43
f	20	44
g	10	45
h	21	11
i	9	12
j	22	13

Link 'k' Direct Input

... for each ANALOG channel. This wire link is installed to connect the Data Logger channels to their associated terminals when an Amplifier Module is not being used to pre-condition the input signal. The 'k' link is removed when an Amplifier Module is fitted.

Link 'm' Isolated Input

... for each ANALOG channel. This wire link is installed to connect the Analog -ve signal input to the associated Amplifier Module. The link is installed for Differential or Isolated input signals being connected to differential or isolated amplifier modules. The link is otherwise not installed.