

STARLOG

**PROLOGGER
Hardware**

Model 7001

Revision 33 Firmware

Copyright Notice

Copyright ©Unidata Australia 1999. All rights reserved. No part of this publication may be reproduced, transmitted, transcribed, stored in a retrieval system, or translated into any language or computer language, in any form or by any means, electronic, mechanical, magnetic, optical, chemical, manual or otherwise, without prior written permission of UNIDATA Australia, 40 Ladner St, O'Connor, Western Australia, 6163, Australia.

Printed in Australia.

IBM™ is a registered trademark of International Business Machines Corp.

Contents

1	INTRODUCTION	1
1.1	How to Use this Supplement	1
2	PROLOGGER OVERVIEW	3
2.1	Programming Overview	4
2.2	How the PROLOGGER Operates	5
2.3	Input Signals	6
2.3.1	Instruments	6
2.4	Outputs	6
2.5	Memory Capacity	7
2.5.1	Log Size	7
2.6	Status Indicators	7
2.6.1	Battery Status LEDs	8
2.6.2	Scheme Status LEDs	8
2.7	The Display and Keyboard	8
2.7.1	Keys Definition	9
2.8	Using the Keyboard and Display	9
2.8.1	Selecting a Display List and List Entry	9
2.8.2	Auto Key Repeat	10
2.8.3	Adjusting a Config Entry	10
2.8.4	Commands in the Config List	10
2.8.5	Using a PIN# (Password)	10
2.8.6	Displaying the Scheme List	11
2.9	Differences with Model 7000 Macro Data logger	12
2.9.1	Input Signals	12
3	SPECIFICATIONS	14
4	POWER SUPPLY	16
4.1	Internal Battery Pack	16
4.1.1	Battery Life	16
4.1.2	Battery Pack Connections	17
4.1.3	Replacing a Battery Pack	18
4.1.4	Recharging NiCad Battery Pack	18
4.2	External Power Supply	19
4.2.1	Connecting an External Power Supply	19
4.2.2	Recharging Batteries	19

4.3	Battery Status Indicators	20
4.4	Monitoring Battery Voltage	20
4.5	Flat Battery Shutdown	20
4.5.1	Saving Memory	21
4.5.2	Auxiliary Memory Back-up Battery	21
4.6	Internal Battery Charger	21
4.7	Automatic Battery Type Detection	22
4.8	The Input Signals Connector Pin-out	22
5	INSTALLATION & CONNECTION	23
5.1	Locating the logger	23
5.2	Instrument Connection	23
5.2.1	Log Start Sense	27
5.2.2	Analog Inputs	27
5.2.3	Counters and Digital Inputs	28
5.2.4	User Power Sources (UPS)	28
5.2.5	High Speed Serial Ports	28
5.3	SDI-12 Serial Digital Interface (optional)	30
5.4	PROLOGGER Initialisation	30
6	INTERNAL CHANNELS	32
6.1	Battery Voltage Monitor (I2, "Batt")	32
7	COMPUTER COMMUNICATION	33
7.1	Computer Connector Pin Designations	34
7.2	Baud Rates	34
7.3	Communications (STARLOG) Protocol	35
7.3.1	Scan Synchronised RS-232 Communication	35
7.3.2	Non-Synchronised RS-232 Communication (default)	36
7.3.3	PROLOGGER Requests (Commands)	36
7.4	Sample Program	38
7.4.1	Simple Interrogation Example	38
8	PROGRAMMING THE PROLOGGER	40
8.1	Memory Layout	40
8.2	Hardware Register Information	41
8.2.1	PROLOGGER Memory Assignments	41
8.2.2	Logger Scan Counter	43
8.3	PROLOGGER - Program	43
8.3.1	PROLOGGER - Operation Sequence	43
8.3.2	PROLOGGER - Program Instructions	43
8.4	Typical instructions	44

8.5	Buffer Control Table	44
8.5.1	Buffer Format Convention	45
9	PROLOGGER CONFIGURATION TABLE	47
9.1	Default Configuration Table	47
9.2	Memory Layout and Protected Memory	48
9.3	Configuration Table Layout	48
9.4	PROLOGGER Linear Calibration Correction	49
9.5	Initialisation via the RS-232	50
9.6	Read/Write Protected Memory	50
10	TEST DIAGNOSTICS	51
10.1	Diagnostic	51
10.1.1	Task Command List	52
A	OPERATING ERRORS	1
B	PROLOGGER REVISIONS	1
C	STARLOG PROTOCOL COMMAND LIST	1
D	USING THE SDI-12 INTERFACE	1

1 INTRODUCTION

The PROLOGGER is a battery powered data collection system manufactured by UNIDATA. It is ideal for automatic data collection at remote, unmanned locations. The PROLOGGER incorporates the latest advanced CMOS technology and intelligent auto calibration techniques to provide a very accurate, low cost, programmable data collection system.

Like other STARLOG products the PROLOGGER has a simple robust construction, is battery-powered, is available at a low cost, and can be universally applied.

The main features of the PROLOGGER are:

- Large 512k battery protected storage area.
- 16 bit conversion resolution on all channels - analog and digital.
- High impedance input channels with large 26 bit dynamic range down to microvolt resolution.
- GSM/Cellular and PSTN telemetry support.
- SDI-12 communications bus.
- Large four line LCD display.

The PROLOGGER provides an upgrade path for the Model 7000 Macro logger. It supports all existing applications. The signal pin-out is the same and existing field terminations can be used.

The PROLOGGER is designed to be operated with the Version 3 STARLOG Software Support Package (Model 6301).

1.1 How to Use this Supplement

This supplement provides technical details for users of the PROLOGGER. It is divided into several chapters. Each describes a different aspect of the device. The appendices include information for advanced users.

The chapters are:

PROLOGGER Overview	Introduces the PROLOGGER and gives a brief summary of its features and operation.
Specifications	Lists physical and performance specifications and explains battery and memory capacity options.
Power Supply	Describes how to change battery packs, use an external power supply and how to test and monitor the power supply.
Installation & Connection	Describes how to connect instruments to the logger and initialising the logger.
Internal Channels	A listing and explanation of two special channels.
Computer Communication	Lists the specifications for communication with a computer and explains in detail the most common method of interface.
PROLOGGER Programming	Describes PROLOGGER programming techniques if you intend to program your own logger.
PROLOGGER Configuration Table	Describes how a PROLOGGER is configured - it identifies and explains that particular part of memory and how it is used.
Test Diagnostics	Explains how to use in-built diagnostic firmware to test and calibrate the PROLOGGER.

2 PROLOGGER OVERVIEW

This chapter provides an overview of the PROLOGGER's features, including its programming and operation.

The PROLOGGER is a major design development in the STARLOG product range. It has an expanded signal capacity and range, and is easier to program. It offers 22 input channels, two high speed serial input/output busses and two outputs. It also provides two power sources for external instruments. The range of scan rates extends from 125 milliseconds to 5 minutes. See page 14 for a list of operational specifications.

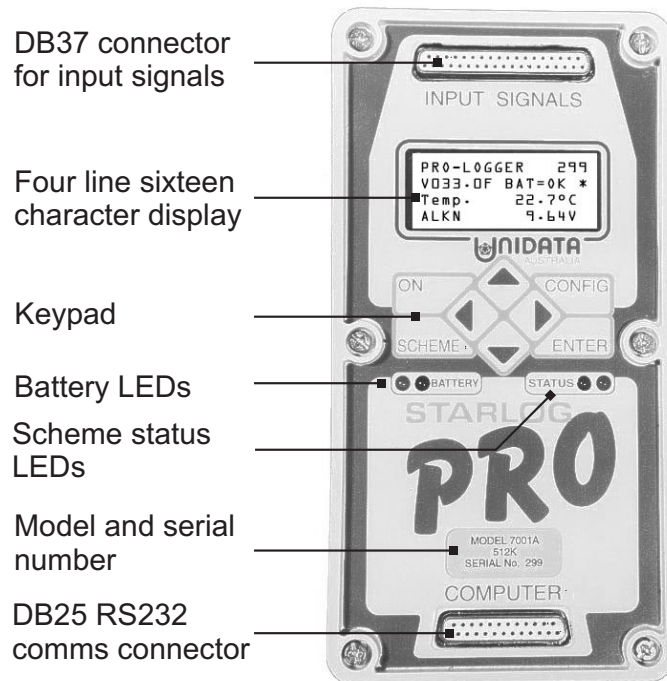

Front Panel Layout

Data and commands are transferred between the PROLOGGER and an IBM or compatible computer using asynchronous RS-232 serial communications. All set-up and adjustments associated with range and calibration are performed in firmware. The PROLOGGER is fully programmable.

The PROLOGGER has a very low power consumption. It is supplied with an internal battery with a typical life of one year. Data is stored in 512k of low power CMOS RAM. An internal crystal-based clock provides accurate time referencing of all recorded data and also controls the adjustable scan rate. The logger's only external connections are:

- A connector (labelled INPUT SIGNALS) for instrument inputs, user power supplies and controls.
- A connector (labelled COMPUTER) used for communication with a computer.

The PROLOGGER and its battery are housed in a small, robust, dustproof enclosure. Exact hardware specifications are listed in Chapter 3.

2.1 Programming Overview

The PROLOGGER is a microprocessor based device designed to be programmed using Unidata's STARLOG Software Package (Version 3). This package, designed to run on IBM PC or compatible computers, creates and implements instructions that control the logger.

Through a series of windows, the STARLOG Software Package allows you to define how and when the PROLOGGER records, what channels to record and what signal types to measure. These definitions are compiled by the package into a list of instructions to be interpreted by the PROLOGGER.

■ The PROLOGGER must be programmed before it will record/log or display readings.

The STARLOG Software generates a set of instructions to program the PROLOGGER. These instructions are explained in the STARLOG Programmer's Supplement (6201).

2.2 How the PROLOGGER Operates

The PROLOGGER must be “initialised” before it can be used. This is done automatically when you load a scheme. Alternatively, you can manually initialise the device (see *PROLOGGER Initialisation* on page 30). Note that when delivered, the PROLOGGER is shutdown to conserve batteries. It must be initialised before use.

The PROLOGGER switches on once per scan. You must specify the scan rate. It performs three operations each time it is switched on: scanning, inter-log analysis, and RS-232 comms check. It then switches off. This sequence occurs every scan interval. It performs a fourth operation, logging, at an interval you specify. These operations are described below.

■ Scanning

Scan rates, which can be from 125 milliseconds to 5 minutes, determine how frequently the logger switches on. When it switches on, the logger scans its input signals. These signals, called the *hardware values*, are recorded in the PROLOGGER memory. The hardware values are updated in the logger memory every scan.

■ Interlog Analysis

After scanning the input signals the logger program performs an *inter-log* analysis of the hardware values, storing the analysed values in a different part of the logger’s memory referred to as the *Register*. The inter-log analysis includes: averaging and storing maximum, minimum and raw values. For example, if a certain channel is programmed to store maximum values of its input, the logger will check to see if the hardware value is higher than the value already stored in the Register. If so, it will update the Register. If not, then it changes nothing and goes to the next instruction. The Register is used to store data between log intervals.

■ RS232 Comms

When the scan occurs at a log interval, the logger program records data found in the Register into another part of its memory. Here, the data remains until the logger is unloaded (or until the entire memory storage space is filled, then earlier stored data may be overwritten when recent data is logged).

2.3 Input Signals

The PROLOGGER has 22 channels for input signals. These are divided into:

- Sixteen analog channels with 16-bit resolution. These can be in any combination of up to 16 single-ended or 8 differential voltage inputs , These channels accept signals from ± 5 millivolts full-scale to ± 5.00 volts full-scale.
- Two high speed serial ports (bi-directional synchronous, eight 16 bit channels on each).
- Four counter input channels (16-bit resolution).
- Two sense input channels (used for LOG START and SDI-12 signals).

The PROLOGGER has a number of operating modes for its analog inputs. Analog inputs are available as low resolution (8 bit, a0 – a15) or high resolution (16 bit, A0 – A15) all with programmable gain settings. (See *PROLOGGER Configuration Table* on page 47.)

For more about inputs see *Installation and Connection* on page 23.

Note: To save power the PROLOGGER only measures signals on channels specified in the scheme. If you load a scheme that only specifies a single channel, the remaining channels are not scanned. If you want to scan signals on all channels, you must load a scheme that specifies all channels.

2.3.1 Instruments

To complement the PROLOGGER, a range of low power instruments and sensors is available. They are designed for direct connection to the PROLOGGER and can use the PROLOGGER's battery or their own power supply.

The PROLOGGER has a broad input range. This means that instruments such as thermocouples, pyrometers, RTDs (like the PT100), strain gauge pressure transducers, precision thermistors and frequency derived signals can generally be connected without amplification or signal conditioning.

2.4 Outputs

The PROLOGGER has two outputs and two power sources for external instruments. The outputs have a wide range of uses, for example they can be used to set off an alarm or switch on an external device.

The four user power sources described in the PROLOGGER Configuration Table are:

- +12 Volts DC unregulated.
- -12 Volts DC unregulated.
- +10 Volts regulated (reference).
- +5 Volts DC regulated, scan synchronised.

2.5 Memory Capacity

The logging duration of the logger depends on the scheme. It is calculated by the software once the scheme is created (see Scheme Information menu).

The calculation includes the following:

$$\text{Number of Days} = (512 - 8) * 1024 * \text{LI}/1440 * 1/\text{LS}$$

LI = Logging Interval (in minutes).

LS = Log Size in bytes.

1024 = The number of bytes in a kilobyte.

1440 = The number of minutes in a day.

2.5.1 Log Size

The Log Size is the sum of bytes used per channel. The bytes used per channel varies depending on the Log Action (raw reading, totalise to 1 or 2 bytes, etc.) and the capacity of the channel. A counter channel may use from 1 to 4 bytes, a serial channel is usually 2 bytes, and an analog channel may use 2 bytes (high resolution) or 1 byte (low resolution).

For example: A typical weather station logging raw readings for wind speed (1 byte), temperature (1 byte), solar radiation (1 byte) and relative humidity (1 byte) every five minutes in a 512k PROLOGGER would theoretically record for:

$$\text{Number of Days} = (512 - 8) * 1024 * 5/1440 * 1/4 = 448$$

2.6 Status Indicators

The PROLOGGER has four LED indicators which flash briefly each scan (5 seconds) to show the status of the battery and logging scheme.

2.6.1 Battery Status LEDs

The top two indicators (labelled BATTERY) show the internal battery status (see *Battery Status Indicators* on page 20).

2.6.2 Scheme Status LEDs

When the PROLOGGER has been programmed with a Scheme (using Version 2 Software) the lower two indicators show the status of the Scheme operation.

LED On	Description	State
None	Waiting to be unloaded.	Stopped
	Waiting for input signals to be connected.	Primed
Green	Connected to signals and waiting to begin logging.	Primed
Green & Red	Actively recording.	Logging
Red	(No Scheme loaded.)	(Invalid)

2.7 The Display and Keyboard

The PROLOGGER has a 64 character Liquid Crystal Display (LCD) and an eight key operator keyboard.

The Display may be activated by pressing the ON key. The Display will turn OFF automatically after a delay of 20 seconds (when no further keys have been pressed).

While the Display is active, the PROLOGGER is in high power mode and uses about 100 times more battery power than in normal scanning mode.

2.7.1 Keys Definition

ON	Activate display and display the first entry of the STATUS LIST .
SCHEME	Displays the first entry of the SCHEME LIST .
CONFIG	Displays the first entry of the CONFIG LIST.
ENTER	Used only in the CONFIG LIST to save the current SETUP entry or perform the current SETUP action.
Up/Down Arrows	Scroll UP ▲ or DOWN ▼ the current list entries.
Left/Right Arrows	Adjust the current CONFIG entry UP in value ► or DOWN in value ◀ . Used only in CONFIG LIST .

2.8 Using the Keyboard and Display

The display shows three lists of useful information.

- STATUS LIST Lists information about the status of battery and channel readings (unscaled).
- SCHEME LIST Lists details of the current Scheme composed using the STARLOG Software V3. This is normally blank unless a Scheme has been loaded.
- CONFIG LIST Lets you adjust some logger configuration parameters (change the scan rate) and execute some useful commands (such as, setting the logger to the “sleep mode”).

Warning: Saving altered Setup Entries using the Enter key will cause data stored in memory above 64K to be lost.

2.8.1 Selecting a Display List and List Entry

Whenever the ON, SCHEME or CONFIG keys are pressed, the first entry in the Status, Scheme or Config list is displayed. The ON key will also turn the Display ON if not already on.

By pressing the scroll keys, you display the next Entry in the list (▼ DOWN key) or the previous Entry (▲ UP key).

Entries may be one or two lines, therefore the scroll keys will move the display UP or DOWN one or two lines, depending on whether the Entry is two lines or not.

2.8.2 Auto Key Repeat

When a key is held down, it automatically repeats. This is a quick way to scan up or down a list of display entries. Releasing the key stops the repeat mode.

2.8.3 Adjusting a Config Entry

To alter a logger Config Entry, scroll to the desired Entry in the Config List and use the Adjust keys ◀ ▶ to adjust the Config Entry to the required settings, then press ENTER to save the new setting permanently. If you do not want to save the Config Entry, press any other key (or no keys at all).

Warning: Pressing the Enter key while displaying a Config Entry with the message "...use & ENTER" on Line 2 will cause data stored in memory above 64K to be lost.

2.8.4 Commands in the Config List

Some entries in the Config List are simple commands, they do not use the Adjust keys ◀ ▶ and they do not cause loss of memory when executed (when ENTER is pressed). A useful command "TURN DISPLAY OFF" is the first entry in the Setup List. Therefore, whenever you have finished viewing the display, press CONFIG, and then ENTER keys.

The display will automatically turn OFF anyway after 20 seconds if no keys are pressed.

2.8.5 Using a PIN# (Password)

The PROLOGGER is fitted with a keyboard and display. This enables you to configure various functions of the logger without a computer. To ensure that only authorised users alter the operation of the logger, an optional 4-digit PIN# (personal identification number) may be entered. The factory default for the PIN# is 0.

To change this PIN#, turn the display ON and then press CONFIG. Press the down arrow until CHANGE PIN# appears in the display. Press the left arrow key to select the digit and then the up or down arrow to alter the digit. Once you have selected a suitable 4 digit number, press ENTER. It is now impossible to change important configuration settings until the PIN# is re-entered.

Once a PROLOGGER has been protected by a non-zero PIN#, you must re-enter the correct PIN# before altering a configuration via the keyboard.

1. Press ON to switch the display on.
2. Press CONFIG.
3. Press the down arrow until ENTER PIN# appears.
4. Select the correct 4-digit code (using the arrow keys) and press ENTER.
5. You can now alter the logger's configuration.

To change the PIN#, you must enter the old PIN# first. A PIN# of 0 means that all settings may be changed without PIN# validation (default).

If you forget the PIN#, the PROLOGGER will operate normally but you will not be able to use the keyboard configuration facility until the PROLOGGER is returned to UNIDATA for service.

2.8.6 Displaying the Scheme List

The Model 7001 PROLOGGER has a four line liquid crystal display (LCD) and eight key keyboard.

Using the Version 3 Software you can set-up the PROLOGGER to display the actual values being recorded by connected transducers. This Scheme Display List contains information similar to the Scheme Test Mode screen. A one-line display entry is provided for each Scheme Test Mode entry. Four entries (lines) are shown on the display at one time.

When you press the up/down scroll keys the display moves up/down this list one line at a time.

To view the readings of each transducer:

Press the ON key and
this will be displayed

```
PROLOGGER 7001
V033.00BAT=0K
```

Press the SCHEME key

```
09:14:50 30APR98
Scheme:RMTEMP
Status:Primed
Memory:121K Free
```

Press the down key ▼

```
Scheme:RMTEMP
Status:Primed
Memory:121K Free
Log Inter 10mins
```

Press the down key ▼

```
Status:Primed
Memory:121K Free
Log Inter 10mins
Temp:22.7degC
```

Continue pressing the down key ▼ until you reach the
end of the display list

Press CONFIG and then ENTER to turn the display off

■ The display turns OFF after 20 seconds, if no keys are pressed.

■ If the instrument being displayed uses a non-linear correction formula (such as a thermistor or wind direction) then the uncorrected (raw) mV reading will be displayed without units.

2.9 Differences with Model 7000 Macro Data logger

2.9.1 Input Signals

The following inputs are different from the Portable Data logger:

Pin	Model 7001	Model 7000
17	Continuous Battery	Unused
19	Sense I/SDI	Unused

3 SPECIFICATIONS

This chapter lists the physical and performance specifications of the PROLOGGER.

Material:	Grey, high impact rigid PVC.
Size:	211 x 108 x 81mm (H x W x D).
Weight:	2 kg including battery.
Operating Temp:	-20°C to 60°C, not affected by humidity.
Scan Rate:	0.125 second to 5 minutes - programmable.
Log Interval:	0.125 second to 1 week - programmable.
Memory:	Low power CMOS RAM 512k (standard).
Time Clock:	Crystal regulated, ±10 seconds per month.
Analog Inputs:	16 channels, 16-bit resolution. Unipolar or Bi-Polar, differential or single ended.
Counters:	4 channels, 16-bit resolution.
STARBUS:	2 high speed serial lines with eight channels on each, 16 bits, bi-directional, synchronous data & clock.
SDI-12:	Optional 1200 Baud instrument channel.
Controls:	2 channels, 1 CMOS output. 1 uncommitted open collector output.
Computer I/O:	Full duplex, serial, RS-232C, baud rates: 300/1200/2400/4800/9600/19200/38400/76800.
Processor:	8 bit, 80C31 micro controller, 14.7456 MHz.
Battery Life:	Alkaline 1 year (typical), or rechargeable NiCad.
Flat Battery Shutdown:	5.6 Volts.
Instrument Power:	+5V DC regulated 100mA. +6.5V DC unregulated, 1mA continuous. +10V DC regulated, 100mA programmable duty cycle (PDC). +12V DC unregulated, 200mA, PDC. -12V DC unregulated, 50mA, PDC.
Signal Specifications	
Counter Channels:	DC to 20 kHz potential free contact or 0–5 V DC digital input.

Analog Channels: Voltage input in four programmable ranges:
-5.00 to +5.00 V, 155 μ V resolution.
-500 to +500 mV, 15.5 μ V resolution.
-50 to +50 mV, 1.55 μ V resolution.
-5 to +5 mV, 155nV resolution.

Input Impedance: >1 M Ω .

Recommended Source
Drive Impedance: <10 k Ω .

4 POWER SUPPLY

This chapter describes the uses of internal and external power supplies for the PROLOGGER. It also describes the low battery shutdown feature. The PROLOGGER is powered by an internal battery. External power sources can be used as an alternative supplies or to recharge batteries (NiCad and Sealed Lead Acid only).

A battery must remain connected at all times to protect data stored in memory. Provision is made for fitting a Lithium back-up battery to protect memory storage if the main battery is removed or fails.

4.1 Internal Battery Pack

The PROLOGGER is powered by its own internal power supply in the form of a battery pack (usually supplied with each logger). Alkaline (Model 6910A) and NiCad (Model 6910B) battery packs are available. The battery pack is located in the base of the logger housing and connected via a three-way socket to the logger.

The PROLOGGER requires a single battery voltage of 6.5 to 10 V DC.

Battery life varies anywhere from a few weeks up to 2 years depending on the logging project (see below).

This section covers:

- Battery life.
- Battery connections.
- Battery replacement.
- Recharging a NiCad battery pack.

4.1.1 Battery Life

The PROLOGGER battery life is influenced by five factors:

- logger scan rate.
- logger program run time.
- External instrument power requirements.
- Display usage.

- Computer communication (RS-232).

■ Formula for Determining Battery Life

The following calculation will determine the battery life for UNIDATA battery packs (Model 6910A):

$$\text{Life (days)} = \left[\frac{\text{ST}}{\text{RT} + 35} \right] * 3300$$

ST = Scan Time (seconds)

RT = Run Time (milliseconds)

... where external instrument load does not exceed 20mA.

The run time is determined by examining Address 1 of the PROLOGGER (Block 0, locations 1 and 2), where the program run time is saved.

■ 6910A battery packs have a maximum life of 3 years.

■ Battery Life Estimation Tables

The following table details the estimated battery life from loggers with various scan rates and battery types. This table assumes a program run time of 12 milliseconds (approximately 40 instructions).

Scan Rate	Model 6910B	Model 6910A
	Life (days)	Life (days)
0.25	12	16
1	30	66
5	40	330
10	40	660

Model 6910A – 10 Ah Alkaline Battery Pack.

Model 6910B – 4 Ah Nickel Cadmium Battery Pack.

4.1.2 Battery Pack Connections

The Model 6910 battery packs are manufactured with a 3-way socket connector that plugs into the Model 7001 PROLOGGER.

Users who manufacture their own replacement battery packs may purchase connectors from a Molex dealer or simply re-use the wire & connector from the old battery pack. The connector type is Molex brand 050-57-9403 70066-0177 shell with type 016-02-1125 71851-0224 crimp terminals.

4.1.3 Replacing a Battery Pack

All recorded data will be lost when the battery pack is disconnected (unless the auxiliary battery is installed (see page 21). Ensure the PROLOGGER has been unloaded before replacing the battery.

To replace a battery pack:

1. Remove the PROLOGGER lid by unscrewing the six lid screws.
2. Depress the small retaining clip securing the battery plug and disconnect the battery cable.
3. Lift out the black metal battery retaining plate and remove the used battery pack.
4. Insert a new battery pack and replace the metal retaining plate making certain not to crush the battery wires.
5. Reconnect the new battery and the PROLOGGER will begin operating.
6. Replace the lid into PROLOGGER base and tighten the six lid screws.

The PROLOGGER will not be damaged if battery wires are accidentally reversed.

ENVIRONMENT FRIENDLY - UNIDATA uses only mercury-free alkaline cells in battery packs. UNIDATA or your battery manufacturer will accept battery packs returned for recycling.

4.1.4 Recharging NiCad Battery Pack

The NiCad Battery Pack can be recharged by a mains power pack or a solar powered recharge system. You can also recharge a battery pack on site using an external power source. (See the next section.)

4.2 External Power Supply

An external power source can be connected to the PROLOGGER. External power can be used with an Alkaline or NiCad battery pack as a backup power source or simply on its own.

A mains power pack and a solar power pack are available from UNIDATA.

The supply voltage to the PROLOGGER must be maintained at all times to ensure correct logger operation and data integrity. (See optional Auxiliary Memory Back-up Battery on page 21.)

The voltage to the logger must be in the range of 9 V to 20 V and able to supply a load of 100 mA peak (increasing to 500 mA when recharging a battery).

4.2.1 Connecting an External Power Supply

To install an external power supply:

1. Connect +ve to pin 16 of the INPUT SIGNALS socket (terminal 1 of the Field Termination Strip).
2. Connect -ve (common) to pin 34 of the INPUT SIGNALS socket (terminal 2 of the Field Termination Strip).

Pins 50 - EXT Power and 51 - GND on the 7001C Field termination Strip are generally used for charging external batteries using a solar panel.

4.2.2 Recharging Batteries

With a NiCad battery pack installed a PROLOGGER can be recharged from a solar panel, mains power pack or other DC power source. The input voltage should be between 11V and 20V.

NiCad Battery Packs require several charge/discharge cycles before their full charge is retained. Therefore ensure the PROLOGGER has been fully charged (connected to solar recharge or mains power pack) then left to discharge at a high scan rate.

4.3 Battery Status Indicators

The PROLOGGER measures its internal battery voltage every scan. If the battery voltage falls below certain preset levels, the Battery Status LEDs on the front panel will change state.

GREEN	RED	BATTERY STATUS	ALKN	NiCAD	LCD DISPLAY
ON	OFF	Battery OK	>7.2V	>7.2V	OK
ON	ON	Battery Low (Replace soon)	<7.2V	<7.2V	Low
OFF	ON	Battery Flat (Replace immediately)	<6.6V	<7.1V	Chg
OFF	OFF	Not Operating (“Sleep” or “Shutdown” Mode)	<6.2V	<7.0V	Bad

Whenever an external power source greater than 11V DC is connected to the logger, the internal battery is bypassed (and/or recharged). The logger operates from the external power, but will automatically use the internal battery if external power falls below 11V DC or fails altogether.

4.4 Monitoring Battery Voltage

The most recent battery voltage measurement is stored in the logger memory and can be displayed or logged.

The PROLOGGER saves the voltage measurement at Address 236 (Internal Channel I2, also called, “Batt”, see page 32). Use Test Mode to display the internal channels.

4.5 Flat Battery Shutdown

The logger also monitors the battery voltage when in *sleep mode*. If the voltage falls to a level that could cause faulty operation, the logger enters *shutdown* state and will not scan, communicate with a computer or activate the display. In addition, all equipment power loads are disconnected (counter channels and pin 18 continuous power) to preserve memory.

The Flat Battery Shutdown voltage limit is 5.6V.

4.5.1 Saving Memory

A logger in “Shutdown” or “Sleep” mode will preserve its memory for many weeks. To recover information stored in the logger:

Connect a computer to the logger and attempt to “Unload” it.

If the logger was in sleep mode, it will *wake-up* and unload normally. If it was in shutdown mode, connect an external power source to the logger (such as a new battery pack, see page 18 for details). The logger will *wake-up* and unload normally.

The external power must be connected without disconnecting the internal “Flat” battery (unless the optional memory back-up battery is installed). Follow the procedure in *Connecting an External Power Supply* on page 19.

4.5.2 Auxiliary Memory Back-up Battery

An optional Lithium battery (Model 6909A) can be installed to provide memory back-up power when the main battery pack is removed or fails completely. The battery type is a 3.4VAA lithium cell with wire leads (SAFT LS14250 or similar).

The status of the auxiliary battery is monitored by the logger. If the battery requires replacement (or is not installed) an asterisk (*) is displayed adjacent to the main battery status.

To check auxiliary memory back-up battery:

1. Press the ON key firmly. The following is displayed:
PROLOGGER 900
V033.00 BAT=OK *
2. This indicates the auxiliary battery is either not installed or needs replacement.

In all loggers the auxiliary memory back-up battery status is indicated in Bit 6 of Register 33 (see section 8.2.1).

4.6 Internal Battery Charger

The PROLOGGER has an inbuilt battery charging circuit designed for continuous recharging of NiCad and Sealed Lead Acid batteries as well as providing regulated power to the logger when operating from external power.

4.7 Automatic Battery Type Detection

The PROLOGGER automatically detects which type of battery is installed and sets the voltage thresholds accordingly. The logger also enables the battery charging circuit when a NiCad battery is installed.

ALKLN or NiCad will be displayed on the LCD according to which type of battery is installed.

If external power is used and no battery pack is installed, the LCD will indicate ALKLN.

4.8 The Input Signals Connector Pin-out

The table on page 24 lists each pin in the INPUT SIGNALS connector by number. Next to the pin number is a description of the signal for which this connection is designed. The last column lists the high resolution channel mnemonic used by STARLOG to refer to this connection.

5 INSTALLATION & CONNECTION

This chapter provides information necessary to install a PROLOGGER. It includes:

- A list of the connections of the INPUT SIGNALS connector.
- Signal specifications for each connection.
- How to initialise a PROLOGGER.

5.1 Locating the logger

The PROLOGGER may be installed in nearly any environment with the following provisos:

- It should not be exposed directly to the weather. If it is to be used externally, it should be housed in a weatherproof enclosure.
- It should be mounted away from electrical noise sources (such as electrical contactors and radio transmitters). In all cases signal leads should be shielded and kept as short as possible.

Wherever possible, install the PROLOGGER in a protected location exposed to the least temperature extremes. This will increase the battery life, and improve clock and signal measurement accuracy.

5.2 Instrument Connection

You connect instruments to the PROLOGGER via the 37-pin socket located on the logger's front panel and labelled INPUT SIGNALS. For ease of use you can plug a Field Termination Strip into this connector. Each input is referred to as a channel in the STARLOG Software Package.

■ Field Termination Strip

This extends the INPUT SIGNALS connector to a row of numbered screw terminals. The Field Termination Strip (Model 7100C) and its manual (supplement 7012) are available from UNIDATA.

The pinouts of the INPUT SIGNALS CONNECTOR is shown below.

The following table lists each pin in the INPUT SIGNALS connector by number. Next to the pin number is a description of the signal for which this connection is designed. The last column lists the high resolution channel mnemonic used by the STARLOG Software to refer to this connection.

Pin	Signal Description	Channel
1	Analog ground	
2	Analog input	A1 (A1+ve)*
3	Analog input	A3 (A3+ve)
4	Analog input	A5 (A5+ve)
5	Analog input	A7 (A7+ve)
6	Analog input	A9 (A1-ve)
7	Analog input	A11 (A3-ve)
8	Analog input	A13 (A5-ve)
9	Analog input	A15 (A7-ve)
10	Sense input BIT 3 (Log Start, MASK 8)	SENSE 0
11	16 bit counter input (20kHz)	C0
12	16 bit counter input (20kHz)	C2
13	High Speed Synchronous Serial Port Clock (TTL level input and output)	HSIO Clock 1
14	High Speed Synchronous Serial Port Clock (TTL level input and output)	HSIO Clock 0
15	Control, Open collector output, 30V, 100mA drive, 20ms pulse width	OUT 1
16	External power +12V (or recharge)	Power Input
17	+6V continuous power for external instruments (1mA maximum)	Micro Power
18	Scan synchronised +5V regulated UPS or HSIO Sync (@30mA max)	Sync Power or HSIO Sync

Pin	Signal Description	Channel
19	Sense input BIT 1 (MASK 2)	SENSE 1 /SDI-12
20	Analog input	A0 (A0+ve)
21	Analog input	A2 (A2+ve)
22	Analog input	A4 (A4+ve)
23	Analog input	A6 (A6+ve)
24	Analog input	A8 (A0-ve)
25	Analog input	A10 (A2-ve)
26	Analog input	A12 (A4-ve)
27	Analog input	A14 (A6-ve)
28	Digital ground	Digital ground
29	16bit counter with prescale (20kHz)	C1
30	16bit counter with prescale (20kHz)	C3
31	High Speed Synchronous Serial Data Port (TTL level input and output)	HSIO data 1
32	High Speed Synchronous Serial Data Port (TTL level input and output)	HSIO data 0
33	Control, Open collector output, 30V, 100mA drive, 20ms pulse width	
34	Power ground	Power ground
35	+10V regulated user power source	User power
36	-12V, 5mA unregulated user power supply	User power
37	+12V, 200mA unregulated user power supply	User power

*The channel assignments for inputs in brackets refer to differential signals.

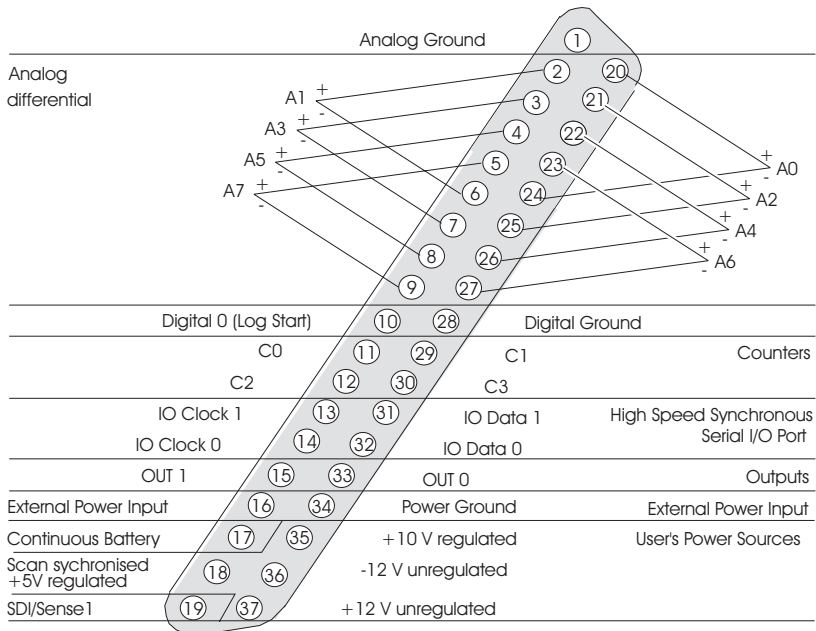
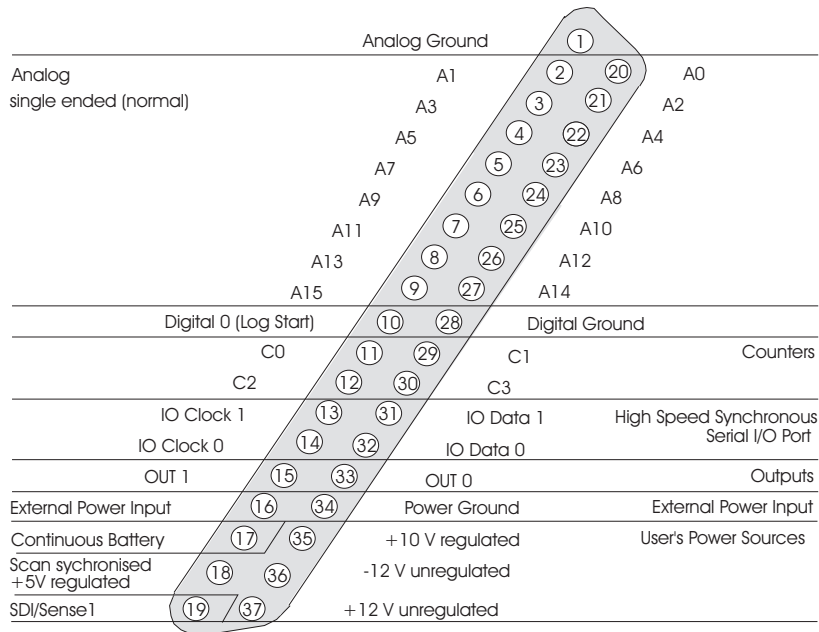

5.2.1 Log Start Sense

Normally, the PROLOGGER only begins to record when an instrument is connected via the INPUT SIGNALS input. To sense this condition, Pin 10 (Log Start Sense 0) of the INPUT SIGNALS socket is grounded (connected to Pin 28). The PROLOGGER program may then sense this condition by the `BJMPN 32, #8, Branch Label` instruction which branches when the INPUT SIGNALS are not connected. See the description of the startup.INCLUDE file in the Programmer's Supplement (No. 6201) for further information.

Warning: The STARLOGGER will not begin recording unless the LOG START Sense is connected to ground (Pin 28). LOG START is automatically connected to ground when the Model 7100 Field Termination Strip is used.

5.2.2 Analog Inputs

Analog inputs can be used as low resolution (8 bit) or high resolution channels (16 bit). Their usage depends how you refer to the input in the STARLOG software. The software interprets analog inputs as low resolution channels when you refer to them as a0 – A15 and high resolution channels when you refer to them as A0 – A15.

All analog channels are programmable to carry a signal in one of four ranges:

-5.00 to 5.00V	155 μ V resolution
-500 to 500mV	15.5 μ V resolution
-50 to 50mV	1.55 μ V resolution
-5 to 5mV	155nV resolution

Input impedance (when the logger is active) is greater than 1M Ω . Load impedance (when the logger is inactive) for signals less than 500 mV is greater than 1M Ω . For signals greater than 500mV it is 10k Ω . The recommended source drive impedance is <10k Ω .

Analog channel calibration coefficients are stored in the configuration table (see page 47 for details).

5.2.3 Counters and Digital Inputs

Counter and Digital inputs are DC inputs suitable for 20 kHz potential free contacts or 0–5V to 0–12V DC digital input.

Maximum pulse rate to the counters is 20 kHz. Pulse rates must also be related to scan rate, to ensure counters do not overflow before being scanned by the PROLOGGER.

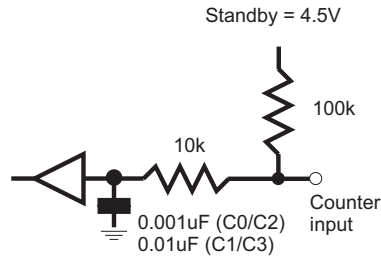

5.2.4 User Power Sources (UPS)

The User Power Sources (Pins 18, 35, 36, 37) are intended to power instruments associated with the PROLOGGER. The full load output capability is 350mA in pulsed mode and 175mA (50% duty cycle) in continuous operation. The standing battery drain with the UPS switched ON (and no external UPS load) is 15mA.

The Scan Synchronised UPS (Pin 18) switches on and off in sync with the logger scan. Any loads connected to these outputs will contribute to the drain on the PROLOGGER battery (and reduce battery life).

The other User Power Sources (Pins 35, 36, 37) are programmed to switch on and off by setting three variables (Prescan, Ontime and Offtime) in the PROLOGGER Configuration Table. See *PROLOGGER Configuration Tables* on page 47 details.

5.2.5 High Speed Serial Ports

There are two serial ports:

Port 0	Pin 13 (Clock 1)
	Pin 31 (Data 1)
Port 1	Pin 14 (Clock 0)
	Pin 32 (Data 0)
	Pin 18 +5V sync signal

These ports are read each logger scan. The Sync signal (Pin 18) is used to indicate to the remote equipment that a logger read scan is about to begin. This signal is used to load the serial shift register(s) in the remote equipment in preparation of being read.

The first data bit LSB must be present on the Data (0/1) signal within 7ms after the Sync signal.

Serial transfer rate is 50 microseconds per bit with a 30 microsecond gap between each byte. See the timing diagrams for Serial In and Serial Out below.

Every 1mS a logger interrupt sequence adds a 50 microsecond delay to the serial transfer sequence. Transfer starts with the least significant bit of the least significant byte and each clock reads the next most significant bit.

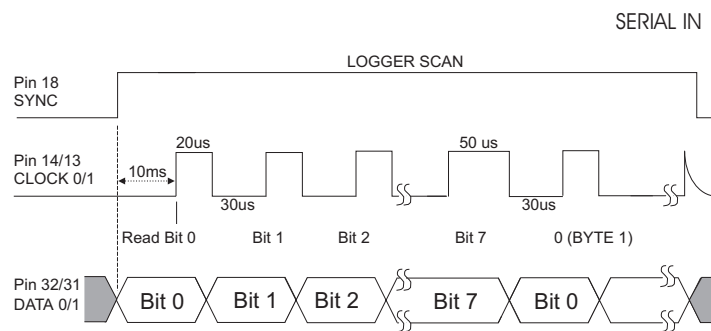

Serial In Timing Diagram.

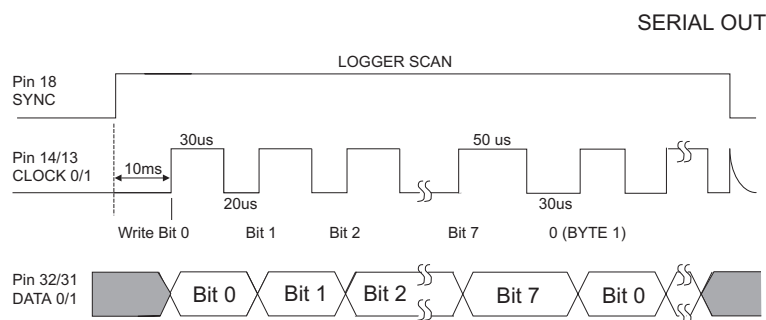

Serial Out Timing Diagram

5.3 SDI-12 Serial Digital Interface (optional)

The PROLOGGERS support the U.S.G.S. SDI-12 standard for serial data interchange between the logger and intelligent instruments.

SDI-12 is implemented as an alternate use of Sense 1 (Pin 19). Up to ten SDI-12 compatible instruments may be connected to this bus. Programming the SDI-12 interface is supported in the STARLOG Version 3 Software.

See Appendix D - *Using the SDI-12 Interface* details on how to use the SDI-12 Interface.

5.4 PROLOGGER Initialisation

The STARLOGGER is normally stored and delivered to you in *sleep* mode to conserve batteries. You *must* load a scheme into the logger before it can be used.

In normal use, the PROLOGGER will not require initialisation. If however, the logger does not appear to scan at the correct rate, it may need re-initialization.

Any of the following actions will (re)initialise the logger:

- Loading a Scheme into the logger.
- Executing the "RESET LOGGER" command in the Config List.
- Using the ALT-I command in Diagnostics. (See the STARLOG Software Package.)
- Disconnecting, then re-connect the battery after a ten second delay.
WARNING: data stored in memory will be lost.
- Adjusting and saving any of the Config Entries.

During initialization, the logger's firmware and Configuration Table is check-summed to confirm its integrity. The Scan Counter is set to the logger Scan Rate and other housekeeping functions performed.

See the STARLOG User's Manual for more information.

6 INTERNAL CHANNELS

The PROLOGGER has four internal channels. These are presented as high resolution values (signed 16 bit) in Register Addresses 232 to 239 as detailed below:

Name	Description	Register Address
I0 (Temp)	logger Temperature (0.1221°C per bit)	232
I1 (10V)	10V reference (1.221 mV per bit)	234
I2 (Batt)	logger battery (or supply) voltage (1.221 mV per bit)	236
I3 (5V)	5V scan synchronised reference voltage (1.221 mV per bit)	238

The values of these internal channels are available for recording (logging) or use in computations in the User Log Program. Typical uses may be to provide high accuracy corrections to bridge measurements (strain gauge/PT100 etc.) referenced to the 10V or 5V supplies.

The temperature (which is in thermal contact with the Analog ground point adjacent to the Input Signal connector) can be used to provide cold junction compensation for thermocouples connected to the Input connector.

6.1 Battery Voltage Monitor (I2, “Batt”)

Battery voltage is automatically monitored by the logger and recording will cease if the battery falls below a defined threshold (the logger goes into sleep mode). The threshold is defined in the Configuration Table (see page 47). The battery state is also displayed on the Battery Status LEDs while the logger is operating (see page 20 for details).

7 COMPUTER COMMUNICATION

The PROLOGGER uses standard asynchronous, RS-232 serial communications to connect to IBM PC or compatible computers.

You can load and unload schemes and data using the RS232 connection . About half of the pins in this plug are allocated a function. The rest are reserved for future use. This chapter:

- Explains how to set the baud rate.
- Describes the communications protocol.
- Includes a sample communication program.
- Includes a table listing pin allocations.

The communication format is:

- RS-232C compatible.
- 300 to 76800 baud (9600 baud is default - see page34 for details).
- 8 data bits.
- 1 stop/start bit.
- No parity.

You can connect a computer to the PROLOGGER via the 25-pin socket (labelled COMPUTER) located on the logger's front panel. Model 6602A 25-25 pin and Model 6602I 25-9 pin cables are available from UNIDATA.

7.1 Computer Connector Pin Designations

The following table lists each pin in the COMPUTER connector by number. Next to the pin number is a signal description. The last column explains how the pin is used.

Pin	Signal Description	Usage
1	Signal and logic ground	Ground
2	Serial data signal to logger	RxD
3	Serial data signal from logger	TxD
4	RTS from computer	RTS
6	DSR from logger	DSR to CPU
7	Signal Ground	GND
10	Mode	
15	Baud Rate Select (See section 7.2.)	
16	Baud Rate Select	
17	Baud Rate Select	
20	from computer (not used)	DTR
25	Remote Telemetry Control from logger	OUT 0

All other pins are not connected and reserved for future use.

Notes

1. The RTS signal from the computer will activate the logger even between scans. The logger may respond with a prompt (CR) immediately the RTS becomes true or wait until the next scan (depending on communication mode settings).
2. CTS signal is not used to synchronise communications between the logger and computer, this is achieved by the logger prompt (CR). The DSR is true whenever the logger scan is active.

7.2 Baud Rates

The communication baud rate is selected on the COMPUTER connector on the face of the logger. Note that PC/XT and slow PC/AT computers can only communicate up to 9600 baud. Fast PC/AT and 386 machines can communicate at 19200.

To select the RS-232 baud rate (other than the default 9600* baud) you must link one (or more) of the COMPUTER connector pins 15, 16 and 17 to ground (pin 7).

Pin 15	Pin 16	Pin 17	Baud Rate
GND	NC	GND	300
NC	GND	NC	1200
NC	GND	GND	2400
GND	GND	NC	4800
NC	NC	NC	9600*
NC	NC	GND	19200
GND	NC	NC	38400
GND	GND	GND	76800

NC = Not connected.

GND = connected to ground.

Note that pin 14 is reserved.

7.3 Communications (STARLOG) Protocol

This section describes the communications protocol common to all STARLOG products. See Appendix B *Starlog Protocol Command List for a complete list of STARLOG protocol commands.*

7.3.1 Scan Synchronised RS-232 Communication

At the end of every scan (5 seconds usually) the logger will check to see if the computer interface is connected. If the interface is connected, the logger sends a prompt to the interface (host computer). This prompt is an ASCII asterisk followed by a carriage return (CR).

The logger then waits 0.5 second for a request from the host computer. If no request is received by the logger, the logger powers down (switches off) until the next scan (5 seconds usually).

While the logger is communicating with the computer, it will remain active (in high power mode). However, any logger scans that are due will be processed simultaneously with ongoing communications.

7.3.2 Non-Synchronised RS-232 Communication (default)

If the PROLOGGER is set to operate in non-synchronised mode the RS-232 communication protocol timing is slightly different.

The logger will immediately enter communications state (and send a prompt) whenever the Request To Send (RTS) line becomes true (ON/HIGH). It does not wait until the end of the next logger scan.

If a logger Scan occurs during RS-232 communications, the scan will be processed.

7.3.3 PROLOGGER Requests (Commands)

A PROLOGGER has three basic commands - GET, PUT and KILL. The (G)ET and (P)UT commands only access the first 64K of memory.

For memory sizes greater than 64K, lowercase equivalents of these commands serve as an extended protocol commands. That is, `g` performs an extended GET command. All extended protocol commands require a checksum following the message.

If the logger receives an invalid command it will be ignored. Other commands are used to maintain and initialise the Configuration Table (see page 47 for details).

See Appendix 7.3C - *Starlog Protocol Command List* for a complete list of STARLOG Protocol commands.

■ GET (and (g)et) Commands

GAAAASS where G is the GET command, AAAA is the 16 bit address (MSB/LSB) and SS is the number of bytes required. A zero in the SS command corresponds to 256 bytes. AAAA is the command for a 16 bit address in the first 64K memory storage of the logger.

```
Gaaaaaaaaassscccc
```

Where: `g` is the get command

`aaaaaaaa` is the 32 bit start memory address (MSB...LSB).

`ssss` is the 16 bit number of bytes to transfer.

`cccc` is the 16 bit checksum.

To read 256 bytes from address 768 into the host computer the command is:

```
G030000
```

■ PUT {and (p)ut} Commands

```
PAAAASS
```

paaaaaaasss...put data...cccc similar to the GET command except that data is sent to the logger immediately following the command string.

cccc the 16 bit checksum for the (p)ut command includes the address, size and data fields (i.e., everything except the “p” command and the checksum itself) and is sent MSB/LSB.

For example, to reset the logger timer to zero, you will want to put zero into addresses 0004, 0005, 0006 and 0007. The command is:

```
P00040400000000
```

Where: P is the put command

0004 is the offset address (in the registers)

04 is the put data count

00000000 is the data to put

The data format for the GET or PUT is a continuous string of hexadecimal characters. The first two characters correspond to the first byte requested or to be sent, the next two characters is the second byte, and so on. The data string is terminated by a carriage return. A command to retrieve 16 bytes may appear as:

```
G000010
```

the returned data may appear as:

```
00112233445566778899AABBCCDDEEFFmmllCR
```

Where mml = Get data checksum consisting of a 16 bit binary addition of all binary data (not HEX representation) within the retrieved information (excluding the checksum and CR). The checksum is sent as four HEX characters - mm = Most Significant Byte and ll = Least Significant Byte.

Two hex characters are always received or transmitted (most significant digit then least significant digit) even though the number is smaller than 16. For example, 10 decimal is sent or received as 0A.

■ GET or PUT may address any continuous segment of the memory.

■ **(K)ILL command**

K is the KILL command that directs the logger to switch OFF until the next scan cycle (usually 5 seconds).

a command to load location 2 with 0 then exit, would be:

```
P00020100K
```

■ Note: After a GET command, the computer must wait until the logger has sent the GET data before a KILL is issued.

7.4 Sample Program

The following program written in Microsoft QBASIC communicates between the PROLOGGER and an IBM PC or compatible computer.

7.4.1 Simple Interrogation Example

This sample program will issue a command to the logger and display the response from the logger. The commands must be valid commands (see above).

The "ON ERROR GOTO 140" statement is needed to trap (and ignore via RESUME statement) any I/O errors that may occur as the logger powers up and the RS-232 signal lines change state.

Statement 70, sends the command to the logger. Notice that a K command (kill) is appended to the operator request. This shuts the logger down, immediately after the request has been completed to save logger battery power.

Try entering these commands:

G000008	(get 8 bytes from location 0)
G000502	(get 2 bytes from location 5)
G010010	(get 16 bytes (10 hex) from location 256 (Block 1, Location 0)
P00020188G000201	(put 88 into location 2 and

immediately gets the data)

The maximum G (get) size is 127 (7F hex). This is limited by BASIC string length maximum of 255 characters.

```

10  REM PROLOGGER - data transfer example
20  INPUT "Enter data logger command-";A$           'Get Command from
        operator
30  IF A$="" THEN END                               'Finish on c/r
40  OPEN "COM1:9600,N,8,1,CS0,DS0,CD0" FOR RANDOM AS #1
        'Open RS-232 to logger
50  ON ERROR GOTO 140                               'Trap I/O errors
60  INPUT #1,L$:IF INSTR(L$"*")=0 THEN 60
        'Wait for logger prompt
70  PRINT #1,A$;                                     'Send command to logger
80  INPUT #1,L$                                     'Get response from logger
90  PRINT #1,"K";                                   'Send KILL to save battery
100 ON ERROR GOTO 0                                 'Reset error trapping
110 CLOSE #1                                        'Close RS-232 file (channel)
120 PRINT "Data logger Response =";L$              'Print result on terminal
130 GOTO 20                                         'Go back to beginning
140 RESUME                                          'Ignore I/O error

```

8 PROGRAMMING THE PROLOGGER

This chapter describes programming techniques of and memory layout for the PROLOGGER. The contents of this chapter will be useful to those who program and test the logger using the test mode screens provided with the STARLOG Software Package.

For those who use the STARLOG software, this chapter provides important details on the PROLOGGER instructions used by the assembler. For complete programming information consult the STARLOG Programmer's Manual (No. 6201) included with the STARLOG Software Package (Model 6300).

8.1 Memory Layout

The PROLOGGER uses CMOS memory for the:

- Logger Program - the scheme definition.
- Buffer Control Table - Storage of pointers controlling the Log Buffer.
- Hardware Registers - Storage of housekeeping registers.
- Log Buffer - from the end of the logger program to the end of memory for recording measured data.

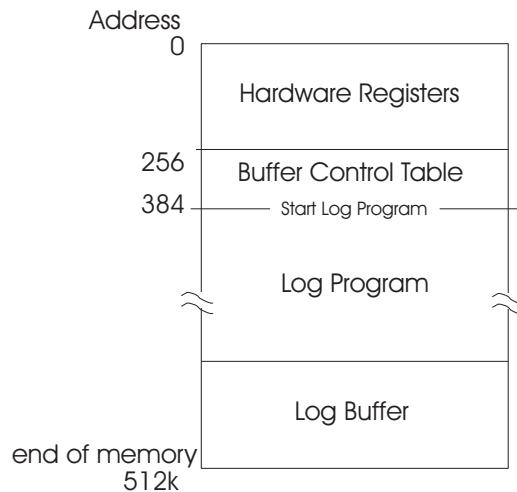

PROLOGGER Memory Map

8.2 Hardware Register Information

The hardware register information can be viewed in Test Mode or used by programmers wishing to write their own unload and analysis programs. The table below gives a description of each register numbered 0 to 255. For multiple byte registers the convention used is – least significant byte to most significant byte. A byte may contain a number from 0 to 255 (8 bits) and for calculating multiple byte numbers the first byte is added to the second byte times 256 plus the third byte times 256 times 256, etc.

eg. The four byte number 1234 would give:

$$1 + (2 * 256) + (3 * 256 * 256) + (4 * 256 * 256 * 256) = 67305985$$

Arithmetic instructions using 32-bit unsigned integers can represent values from 0 to 4294967295.

8.2.1 PROLOGGER Memory Assignments

The PROLOGGER operating the standard instruction set, has the following fixed memory assignments in the Hardware Register:

(Pin xx) refers to a pin of the INPUT SIGNALS connector.

Address	Size	Description
0	1	Software Revision Number (33 onwards)
1	2	logger runtime in milliseconds (16 bit integer)
3	1	Error flags (see Appendix A)
4	4	logger scan counter (32 bit integer)
8	3	Reserved
11	2	MSB of address (bits 8-23) used in LDBLK and MVBLK instructions
13	2	Reserved
14	2	Binary states of analog channels
16	8	Eight analog channels (a0 to a7) unsigned low resolution representation (8 bit) of the 16 bit channel (A0 to A7) measurement
24	8	Counter channels

Address	Size	Description
32	1	Digital input values (normally high) Bit 0..2 Baud Rate: 000=9600; 101=300; 010=1200 011=2400; 110=4800; 001=19200; 100=38400; 111=76800 Bit 3=0 Log Start (SENSE 0) connected to GND Bit 4=0 Reserved Bit 5=0 SDI-12 (SENSE 1) not active Bit 6 High speed serial DATA 1 Bit 7 High speed serial DATA 0
33	1	User Power Supply status register Bit 0 = 1 UPS will be ON next scan Bit 1 = 1 UPS was ON this scan Bit 2 = 1 UPS is currently ON Bit 3 unused Bit 4 = 1 RTS is not active Bit 5 = DTR not active Bit 6 = 1 Memory Backup Battery OK Bit 7 = 1 unused
34	1	Arithmetic status register set by ADD, SUB, MUL, DIV instructions. Bit 2 = Arithmetic overflow Bit 7 = Arithmetic carry Logic status register set by CMP (compare) instruct. Bit 4 set Operand 1 =Operand 2 Bit 5 set Operand 1 < Operand 2 (unsigned) Bit 6 set Operand 1 < Operand 2 (signed)
35	1	Reserved
80	6	Software stores Scheme Name here.
200	32	16 x analog channel A0 (Pin 1) signed 16 bit channel (155 μ V/bit)
232	2	PROLOGGER internal temperature signal \pm 500°C range (0.1°C resolution/bit)
234	2	10V reference (0.01V/bit) (Pin 35)
236	2	Supply (Battery) voltage scaled 0.01V/bit
238	2	5V scan synchronised reference voltage (0.01V/bit) (Pin18)

8.2.2 Logger Scan Counter

This is incremented every scan and when loaded with a scheme represents the number of scan intervals past 1/1/1980 at 00:00:00.

8.3 PROLOGGER - Program

The PROLOGGER is a programmable data recording unit. The program resides in the first part of the logger's main memory (after the Hardware Registers and Buffer Control Table). It is defined by a user and loaded into logger memory from the host computer.

The logger program is executed every logger scan (from 0.125 of a second to 5 minutes). The first instruction in the logger program is at Address 384. The PROLOGGER executes this program until an EXIT instruction is encountered (opcode = 0), then the logger proceeds to service the RS232 port of the computer.

8.3.1 PROLOGGER - Operation Sequence

Every logger scan cycle, the logger hardware performs the following sequence:

1. Read all channels and store their values in the Hardware Register area (Address 0 to 255).
2. Execute the logger program (until EXIT detected).
3. If an RS-232 connection is sensed, send *CR prompt to the Computer Port and wait 0.5 second for a response.
4. Shut down the PROLOGGER and await next scan time.

8.3.2 PROLOGGER - Program Instructions

A logger program starts at Address 384 and consists of one or more instructions. Each instruction is four bytes long (even though some instructions do not use all four bytes). An instruction takes about 0.5 millisecond to interpret and execute.

8.4 Typical instructions

TIMED GOTO	Timer controlled logging sequences
CONDITIONAL GOTO	Event controlled logging sequences
LOAD	Flexible data storage command
(BLOCK) MOVE	Block, Word and Byte move
ACCUMULATE	Block summation for averaging
OUTPUT	Control output sequences
BLOCK CLEAR	Storage initialization
ADDITION	2 & 4 byte operands, 4 byte result
SUBTRACTION	2 & 4 byte operands, 4 byte result
MULTIPLICATION	2 & 4 byte operands, 4 byte result
DIVISION	2 & 4 byte operands, 4 byte result or 2 byte result & remainder
SERIAL INPUT/OUTPUT	Bi-directional Data Bus read/write

8.5 Buffer Control Table

Information to be recorded by the PROLOGGER is stored in one of eight memory areas. Normally only one memory area is used and this occupies all free external memory, starting at Address 1536 and ending at the limit of the PROLOGGER's CMOS memory (512k).

For some log programs requiring lookup tables, the storage starting address may be different.

The storage of channel data in these memory areas (buffers) is controlled by pointer registers held in the Buffer Control Table. Both standard 16 bit and extended 32 bit pointers are supported by Revision #32 firmware. The PROLOGGER's LOG instructions uses one table entry for each buffer (memory area).

An extended (32 bit, 4 byte pointers) Buffer Control Table, illustrated overleaf, is indicated by setting bit 7 of the flag byte (BFLO) in the Buffer Control Table entry for the appropriate buffer(s).

Standard and extended buffers can be intermixed, but only extended buffers can log data past the 64K memory limit.

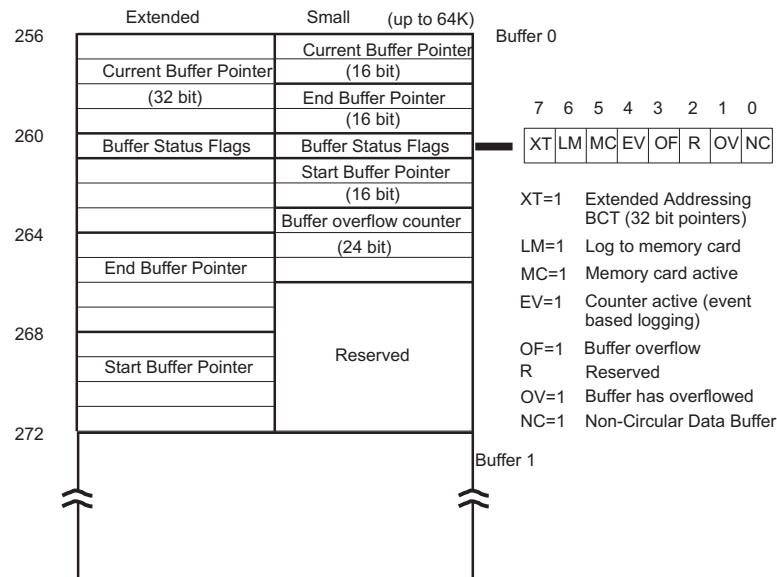

8.5.1 Buffer Format Convention

Information is stored in the data buffers as a sequence of one or more data bytes. Each sequence is called a 'log entry'. There may be many log entries in each buffer.

There are two log entry types:

- Fixed TIME and SIZE.
- Variable TIME and fixed SIZE.

■ Fixed TIME and SIZE

This is the most common form of log entry. Each entry is a fixed number of bytes long and is stored at a fixed interval. For example, recording the wind speed and ambient temperature every hour would produce fixed TIME and SIZE log entries.

■ **Variable TIME and Fixed SIZE**

This form is used with event-initiated log entries. The first 4 bytes of the entry is the time that the event occurred. The time bytes come from Register Address 4 to 7 followed by the log entry (if any). For example, if an event initiated log entry stored the instantaneous value channel 1, the entry would be:

time (4 bytes), channel 1 (1 byte)

9 PROLOGGER CONFIGURATION TABLE

The PROLOGGER has a number of operating modes for its analog inputs. During factory calibration and testing a standard setup and some calibration factors are permanently written into the logger's firmware (in ROM). This part of the firmware is referred to as the Configuration Table and a copy of it is also located in protected memory. If a different configuration is required, you may alter parts of the table.

This chapter describes the Configuration Table and its operation.

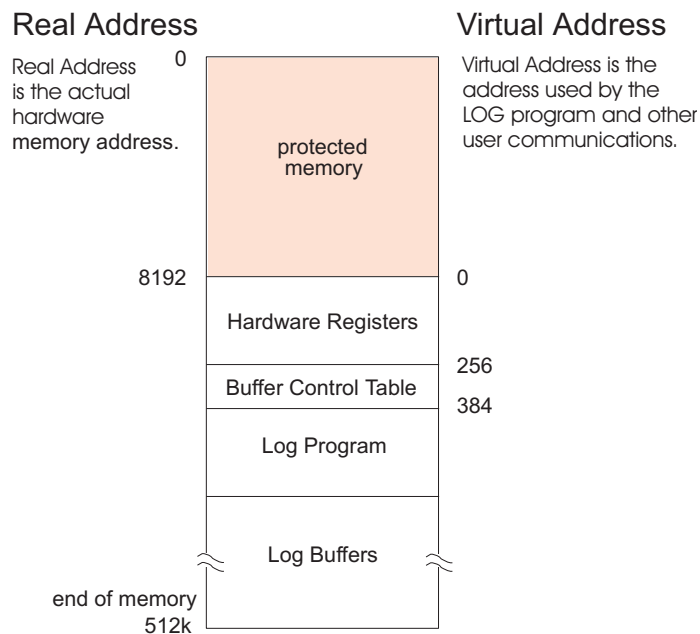

Memory Map of Real and Virtual Addresses.

9.1 Default Configuration Table

The PROLOGGER has a permanent (default) copy of the Configuration Table in a ROM (Read Only Memory) chip. This default version instructs the logger to operate with commonly used settings. A user may alter some (or all) of these default settings to instruct the logger in another manner.

9.2 Memory Layout and Protected Memory

A small portion of the PROLOGGER memory is set aside for housekeeping functions such as I/O buffers and the LCD Scheme Display List. This portion of memory is protected (hidden) from normal logger operations and cannot be read or written by the Log Program or normal GET/PUT commands.

9.3 Configuration Table Layout

The Configuration Table is stored in ROM and may be read by the computer using the *S/s* commands. The configuration table contains an array of 16 bit (LSB/MSB) variables which control many aspects of the PROLOGGER's operation (such as scan rate). The *(i)nt* command is used to permanently alter settings in the configuration table. Some settings may be viewed and adjusted from the Display/Keyboard.

A copy of the configuration table is also stored at Real Address 0 and may be read using the protected *R(ead)* command. This copy is not used for PROLOGGER control, it is available for reference only.

9.4 PROLOGGER Linear Calibration Correction

The PROLOGGER uses the following linear correction formula:-

$$y = gx + o$$

Where: y = corrected value.

x = raw value (from A/D converter).

g = gain coefficient.

o = offset coefficient.

The gain coefficient (g) is made up of the gain coefficients from the appropriate Gain Drive Table gain stage entry. The same applies to the offset coefficient (o).

These coefficients represent decimal numbers (e.g. 0.15) which are stored in the PROLOGGER in a normalised 16 bit form.

■ GAIN

The decimal gain coefficient is multiplied by 8192 to form the PROLOGGER gain coefficient entry. That is, each bit is $1/8192$ or $1.2207E-4$.

$$\begin{aligned} g &= 0.00610 \\ g &= 0.00610 * 8192 = 50 \text{ (or 32 HEX)} \end{aligned}$$

■ Gain coefficients must be POSITIVE.

■ OFFSET

The decimal offset coefficient is multiplied by 8 to form the PROLOGGER offset coefficient entry *in bits*. This offset must take into account the 16 bit A/D conversion as each offset bit has a magnitude of $1/64516$ of the input signal range ($155\mu\text{V/bit}$ in the -5V to 5V range).

For example:

$$\begin{aligned} \text{Gain stage} &= 1, \text{ input range } -5 \text{ to } 5\text{V} \\ \text{each bit} &= 10,000,000/64516 = 155\mu\text{V} \\ \text{therefore,} & \text{ if } O \text{ (offset)} = 1.55\text{mV on a gain of } 1 \\ &= 1.55/0.155 \times 8 = 80 \text{ (50 HEX)} \end{aligned}$$

■ Offset coefficients may be POSITIVE or NEGATIVE.

9.5 Initialisation via the RS-232

Before the PROLOGGER can be used it must be initialised. In some cases, the logger may have stopped scanning to conserve its battery. Normally this initialisation occurs automatically when the logger is loaded with a Scheme.

The command to initialise (or re-initialise) the logger is:

Issss (where ssss is a 4 HEX ASCII number equal to the logger serial number)

The response from the logger following the initialisation is:

CC c/r (where CC is the checksum error in the Configuration Table)

if CC = 00 the resident Configuration Table is valid and the logger has been initialised to use its configuration.

if CC = 01 the resident Configuration Table is corrupted and the logger must be returned to UNIDATA for service.

9.6 Read/Write Protected Memory

There are five RS-232 commands used with the PROLOGGER. They relate to the maintenance and initialization of the Configuration Table. For a complete list of STARLOG Protocol commands see Appendix B.

Command	Description
S	Read the default copy of the Configuration Table from ROM.
N	Read the logger's serial number.
Issss	Initialize the logger with the Configuration Table.
RssssBLLCC	Read from or write to real memory Wssss BLLCCddddccc (same construct as GET/PUT but with checksum of configuration table (cccc = MSB/LSB))
Tssss	Activate diagnostic firmware

ssss in these instructions relates to the 16 bit serial number of the PROLOGGER and acts as a password for protected commands.

cccc is the checksum for the (W)rite command includes serial# (password), address, size and data fields (i.e., everything except the "W" command and the checksum itself).

The 'S' command does not require the serial number password as it only reads the configuration table.

10 TEST DIAGNOSTICS

The PROLOGGER has inbuilt diagnostic firmware activated by the protected command:

```
Tssss = serial number
```

Warning: Once you select diagnostic mode, information stored in the logger may be lost. Always unload the logger before performing test diagnostic requests and reload the logger after diagnostics.

10.1 Diagnostic

This diagnostic offers several tasks used to test and calibrate the PROLOGGER during manufacture. Each task corresponds to a single character sent to the logger via the RS-232 computer interface. After receiving the Protected Command Tssss, the logger enters Diagnostic Mode and sends the message:

```
"PROLOGGER Diagnostics 7001A V33.0F"
```

...followed by a menu of diagnostic commands.

The diagnostic then awaits the entry of a Task Command from the host computer. When a Task Command is received, the logger executes the Task then awaits another Task Command (unless the previous task exited the logger from the Diagnostic Mode).

The serial number must be in hex format and entered Least Significant Byte to Most Significant Byte. For example, the serial number 4001 is hex number 0FA7 and should be entered using the Tssss command in the following order TA70F.

Warning: Diagnostic Mode is intended for technical maintenance. Certain protection features are disabled. TAKE CARE.

10.1.1 Task Command List

■ ANALOG

- A Continuously convert and display single ended channels A0...A7.
- B Continuously convert and display single ended channels A8...A15.
- F Select differential signals.
- H Select High level signals GAIN = 1 (0–5.00.V).
- I Continuously convert and display temperature and battery readings.
- L Select Low level signals GAIN = 100 (0–50mV).
- M Select Medium level signals GAIN = 10 (0–500mV).
- E Select Extra Low level signals GAIN = 1000 (0–5mV).

■ CONTROL

- K Kill (exit from) Diagnostic Mode. Resets logger.
- S Sleep. Shut down logger to conserve batteries when the logger is left unused for long periods.

Warning: logger will be left in an uninitialized state and will not scan. The User must reset the logger using the lssss command (or reload the logger with a valid Scheme).

■ COUNTER

- Y Continuously read and display four Counter channels in hertz (frequency mode).
- T Continuously read and display four Counter channels in binary. Type any character to stop continuous conversion mode.

■ INPUT/OUTPUTS

- J Display Binary inputs UIN0/UIN1.
- O Set Binary output UOT1/(LEDs), UOT0(CNTL), UOT2(ANLG).
- V Test HSIO OUT0 (pulse output).

■ KEYBOARD/DISPLAY

- D Test LCD display.

P Test keyboard.

■ **MEMORY**

X Test memory circuit.

Z Write/Read cycle through 256 data values on RAM address 0.

R Test RAM/ROM shadow.

■ **MISCELLANEOUS**

CR Pressing the Enter key will end the current command (if any) and display the Command Menu.

Esc End the current command.

■ **POWER SUPPLIES**

U Toggle user power supplies.

W Toggle +5V Scan Synchronised Power supply.

Appendix A - OPERATING ERRORS

When the PROLOGGER detects certain error conditions it sets flags in Register Address 3.

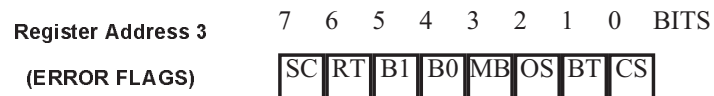

Flag	Meaning	Result
CS	Checksum error or other inconsistency found in the PROLOGGER's Configuration Table or firmware	Fatal
BT	Battery is too low for safe operation.	Fatal
OS	Operator Stop. logger entered "Sleep" mode by command (not due to detected error.)	Fatal
MB	Lithium memory backup battery needs replacement or is not installed (default).	Warning
B1 B0	00 – Battery OK, 01 – Battery Low, 10 – Battery Flat, 11 – Battery Dead	Warning
RT	User Log Program exceeded maximum runtime and was prematurely terminated (no EXIT instruction or corrupted/incorrect Log Program.	Warning
SC	Scan counter fault detected.	Warning

Error flags are divided into WARNING and FATAL errors. FATAL errors cause the PROLOGGER to stop operating and revert to sleep mode. WARNING errors are for information only.

To wake a logger from sleep mode the logger must be connected to a computer and the RTS signal presented. This powers on the logger but does not allow signal scanning or log programs to run, however normal RS-232 communications can occur after the prompt (*CR).

A logger RESET will also set the logger from "sleep" to operating state.

The ERROR FLAGS are READ ONLY and cannot be reset by a log program or a (P)ut command. These flags are only cleared when the logger is RESET (using the I command or Keyboard RESET).

Appendix B - PROLOGGER REVISIONS

This is a list of PROLOGGER firmware. Beside each model is a list of serial numbers and firmware included in each logger when it was released from the factory. Features of each revision are listed. You can use this list to determine your upgrade options.

It is possible to upgrade PROLOGGER firmware within a particular model (contact your UNIDATA office for information).

It is not possible to upgrade firmware across different models.

Model	Firmware	Feature
7001A	Revision 33.0F Serial No. 300	Original release.

Appendix C - STARLOG PROTOCOL COMMAND LIST

There is no response if a GET or READ request has a bad checksum.

Command		Format	Response
G	G/get data block from data logger	GAAAASS	dd—ddcccc(CR)
g		gaaaaaaaaasssscccc	
P	P/put data block to data logger	PAAAASSdd—dd	ecccc(CR)
p		paaaaaaaaassssdd—ddcccc	
W	W/write protected mode	WnnnnAAAASSdd—dd	ecccc(CR)
w		wnnnnaaaaaaaaassssdd—ddcccc	
R	R/read protected mode	RnnnnAAAASS/r	dd—ddcccc(CR)
r		rnnnnaaaaaaaaasssscccc	
T	T/test mode (Diagnostics)	Tnnnnzz	
t		tnnnnzz	
I	Initialise CDT/Firmware	Innnnzz	ee(CR)
S	Unload CDT from PROM	S	dd—ddcccc(CR)
s	Partial Unload of CDT from PROM*	sss	dd—ddcccc(CR)
N	N/number (serial#) of logger	N	nnnncccc(CR)
n		n	
K	K/kill (power down logger)	K	
k		k	

* where the last ss is the size of unload.

C - 1 Standard/Extended Command Differences

Standard (UPPER CASE)

supports 64K (16 bit) address and 256 byte (8 bit) data transfers.

Extended (lower case)

supports 4G (32 bit) address and 16K (16 bit) data transfers except the (p)ut/(w)rite commands which are limited to 1024 byte (10 bit) data transfers.

C - 2 Definitions

AAAA = 4 Hex memory address (16 bit) MSB/LSB

aaaaaaaa = 8 Hex memory address (32 bit) MSB...LSB

SS = 2 Hex size in bytes of transfer (8 bit 00=256)

ssss = 4 Hex size in bytes of transfer (16 bit 0000=65536) MSB/LSB

zz = 2 Hex parameter (8 bit)

dd = 2 Hex data per byte transferred (if applicable)

cccc = 4 Hex data binary addition checksum (16 bit) MSB/LSB excluding the C/c and the cccc fields.

nnnn = 4 Hex logger serial # (16 bit) password LSB/MSB

ee = 2 Hex error code (00=OK)

C - 3 (i)nit Parameters

0 = Init USER configuration table

1 = Load Firmware from RAM

2 = Load USER configuration table from RAM (then init00)

3 = Load FACTORY configuration table from RAM (then init02)

4 = Copy FACTORY configuration table to USER configuration table (then init02)

Error Codes

00 = OK

01 = Bad checksum in ROM

- 02 = PROM/Verify Fail
- 03 = Mirror Fail
- 04 = Bad checksum in RAM firmware

Appendix D - USING THE SDI-12 INTERFACE

D - 1 INTRODUCTION

SDI-12 is an industry-originated, serial digital interface bus designed to allow connection of a wide variety of transducers (meteorological, hydrological, water quality, etc.) to a single SDI-12 data recorder with a single cable bus. The PROLOGGER is such a data recorder. This means that you can, for instance, connect several SDI-12 sensors to a PROLOGGER and not have to worry about combinations of signal types (RS-232, parallel analog, BCD, serial analog, RS-422, etc.).

A unique feature of the PROLOGGER is its ability to operate as an SDI-12 Data Recorder or an SDI-12 Sensor.

This appendix assumes that the reader is familiar with the operation of the SDI-12 Sensor (the Sensor) and the PROLOGGER (the Recorder). For more information see the STARLOG Programmer's Manual, number 6201.

D - 2 THEORY OF OPERATION

When the PROLOGGER sends a "break signal", the Sensor awakes and captures the SDI-12 command following the break signal. If the command is valid, the Sensor reads its address setting to see whether or not its address is in fact being called, or if the address of some other device (at another location) is being sought. If the logger is looking for a different address, the Sensor will go back to sleep until another break signal is received.

If the address being sent belongs to the Sensor, it will scan the instructions coming from the logger to see what action is required. The two most important commands at this time are:

Measure: If the Sensor receives the START MEASUREMENT command, it will report back to the logger the number of parameters enabled for measurement, and that these parameters are available to be sent to the logger immediately.

Data: If the Sensor receives the SEND DATA command, it will send the last parameter readings measured to the PROLOGGER for storage.

D - 3 MASTER MODE (SDI-12 DATA RECORDER)

Using the PROLOGGER as an SDI-12 Data Recorder allows several PROLOGGERS to be connected together.

D - 3.1. SDI-12 Data Recorder Commands

Two Scheme Program instructions are used to control the SDI-12 Master operation:

SDIGET which collects measurements from the nominated SDI-12 sensor, and

SDICONV which converts the collected data for use by the Log Program. Measurements may be converted into fixed point Short Integers (for manipulation by the Scheme), Floating Point Numbers (for logging by the Scheme) or an ASCII string.

- Integers are two bytes.
- Floating Point numbers are 4 bytes.
- An ASCII string is zero byte terminated.

D - 3.2. Data Recorder Coordination

Once an SDI-12 communication has commenced (SDIGET instruction executed) the SDI-12 Bus is busy and will ignore any subsequent SDIGET commands until the active measurement transfer is complete. The measurements are stored in memory, to be converted by a SDICONV instruction. Converted measurements (stored on PROLOGGER channels) may be further processed by the Scheme program and logged.

Because most SDI-12 sensors require considerable time to make their measurements (typically 60 seconds), the PROLOGGER remains powered up awaiting a response from the sensor. This mode of operation usually requires the Scheme Program to initiate SDI-12 Measurements (SDIGETs) prior to the desired Log Interval.

The sequencing of the SDI-12 measurements is under the control of the Scheme Program (which is defined during Scheme Editing.) (See Chapter 7 in the STARLOG Version 3 Software Manual No. 6245.)

D - 3.3. Measurement Errors

If an error occurs during a data collection sequence (SDIGET), the sequence is retried a total of 10 times (configurable). A non-recoverable error causes the SDIGET instruction to report a “null” result and a subsequent SDICONV will not return any data (the channel readings remain unchanged from their last good reading).

D - 3.4. Transparent Mode (Extended Commands)

The PROLOGGER supports a transparent mode of operation that allows ad-hoc commands from an external computer (or modem) to be sent to SDI-12 sensors connected to the SDI-12 bus.

This mode is entered using the STARLOG protected command:

```
tssss01
```

Extended commands may be issued while the Scheme Program is operating, but remember that the extended commands may disrupt the Scheme Program data collection timing. Type

```
Alt+T
```

from within the Communications window to enter this mode.

D - 3.5. SDI-12 Test

To check the operation of the SDI-12 system the following sequence can be tested. Configure the PROLOGGER as SDI-12 Data Recorder to enable SDI-12 operation. At address 384 (Log Program) insert these instructions:

```
128 0 255 4 SDIGET BUSY
129 1 100 0 SDICONV INTEGER,100
128 0 0 0 SDIGET ADDR0
0 BUSY:EXIT
```

This sequence will branch to BUSY whilst SDI-12 bus is busy – then convert the previous measurement to 16 bit integers stored into addr 100 – then issue an SDI-12 measurement sequence to the Sensor at SDI-12 address 0.

D - 3.6. INTERROGATION MODE (SDI-12 SENSOR)

Using the PROLOGGER as an SDI-12 Sensor enables it to be interrogated by another PROLOGGER (or any SDI-12 Recorder). The SLAVE PROLOGGERS do not record their measurements (although they could do so) but instead, send the computed results to the MASTER PROLOGGER for logging. The PROLOGGER will continue to operate at its pre-set scan rate and will perform all the normal logging functions.

STARLOG measurements, RS-232 communications and data logging, co-exist with SDI-12 interrogation.

Whenever an SDI-12 Data Recorder issues a START MEASUREMENT/ SEND DATA sequence, the PROLOGGER immediately responds with the latest parameter readings.

In this mode, the SDI-12 command START MEASUREMENT does not initiate a new measurement cycle and the data is always valid and available for immediate retrieval by the Data Recorder.

D - 3.7. CHANGING THE PROLOGGER ADDRESS

Address 0 is the default address setting for SDI-12; each PROLOGGER is shipped set to address 0.

D - 4 PROLOGGER SDI-12 IMPLEMENTATION

Command	Description	Sensor	Data Recorder
a!	Acknowledge	✓	✗
aI!	Send identification	✓	✗
aV!	Start verification	✓	✗
aM!	Start measurement	✓	✓
aD0!	Send data	✓	✗
Unused Commands			
aM1...9!	Start additional Measurement	✗	✓
aD1...9!	Send additional Data	✗	✗
Extended commands		✗	✓

D - 4.1. DEFAULT SETTINGS

address = 0

retry = 10

of channels = 2

SDI0 channel 1 address = 200 A0

SDI1 channel 2 address = 202 A1

SDI2 channel 3 address = 204 A2

SDI3 channel 4 address = 206 A3

SDI4 channel 5 address = 208 A4

ID string = 011UNIDATA 7001A 2200000<CR><LF>

VERIFY string = 00000<CR><LF>

START string = 00002<CR><LF>

D - 4.2. ALTERING SDI-12 SETTINGS

Change the PROLOGGER Configuration Setting (see Appendix D of the STARLOG Version 3 Software Manual #6245) to adjust SDI-12 settings in the PROLOGGER's Configuration Table. Adjustments are:

address = 0...9

retry count = 1...25

of channels = 0...5

channel 0...4addr = n (location of 16 bit channel in the PROLOGGER Register Block)