

STARLOG

Universal Counter Module

Model 6118A

The Universal Counter Module extends the number of counter channels of a Data Logger. The standard operation mode is set as four 8-bit counters. Alternatively, two 16-bit counters may be configured for use with a Macro Data Logger or STARLOGGER. Cascading of up to eight modules is possible.

This information sheet explains:

- how to configure the module for 8-bit and 16-bit counters
- how to connect the module to instruments and a Logger
- which channels to use in a STARLOG Scheme
- how to "daisy-chain" modules together

1. Configuration Switch Settings

Function	1	2	3	4	5	6	7	8
Counters 2 and 3 = 8 bit	on	off						
Counter 2 = 16 bit Counter 3 not available	off	on						
Counters 0 and 1 = 8 bit			on	off				
Counter 0 = 16 bit Counter 1 not available			off	on				
Reset counter 0 each scan					on			
Accumulate counter 0					off			
Reset counter 1 each scan						on		
Accumulate counter 1						off		
Reset counter 2 each scan							on	
Accumulate counter 2							off	
Reset counter 3 each scan								on
Accumulate counter 3								off

2. Connections

Counter Module Terminals		MACRO		Starlogger & PDL	
Number	Function	pin	FTS*	pin	FTS*
1	Counter 3	Connect to your instruments			
2	Counter 3 ground				
3	Counter 2				
4	Counter 2 ground				
5	Counter 1				
6	Counter 1 ground				
7	Counter 0				
8	Counter 0 ground				
9	5 volt sync	18	14	13	15
10	Digital Ground	28	13	23	14
11	Data Out	32	11	21	11
12	Clock	14	12	9	12
13	Data In	from other Counter Module – see 4.			
14	Battery +ve (6 – 12V)	to external battery			
15	Battery ground				

FTS* = Field Termination Strip. If an FTS is used, the Scheme must be defined as having the SITE ID option fitted.

3. Using Counters in a STARLOG Scheme

Using STARLOG Software Version 2.1 and above, create a Scheme with the following channels:

- a) a serial channel designated with a capital S for each 8-bit counter (e.g., S0, S1, S2, etc)
- b) a serial channel designated with a lowercase s for each 16-bit counter (e.g., s0, s1, s2)

See the diagram on the next page and notes on page 5.

If necessary, see the Hardware Supplement that came with your logger to determine where data on these channels is stored in the Logger's memory (hardware register). These extra counters are read by a SERIN instruction.

4. Using More Than One Counter Module

Counter modules may be "daisy chained" onto one serial input. This is done by connecting terminal 11 (Data Out) of the second module to terminal 13 (Data In) of the first (the one connected to the Logger).

Connect each module to the Logger's Clock, +5 sync and digital ground.

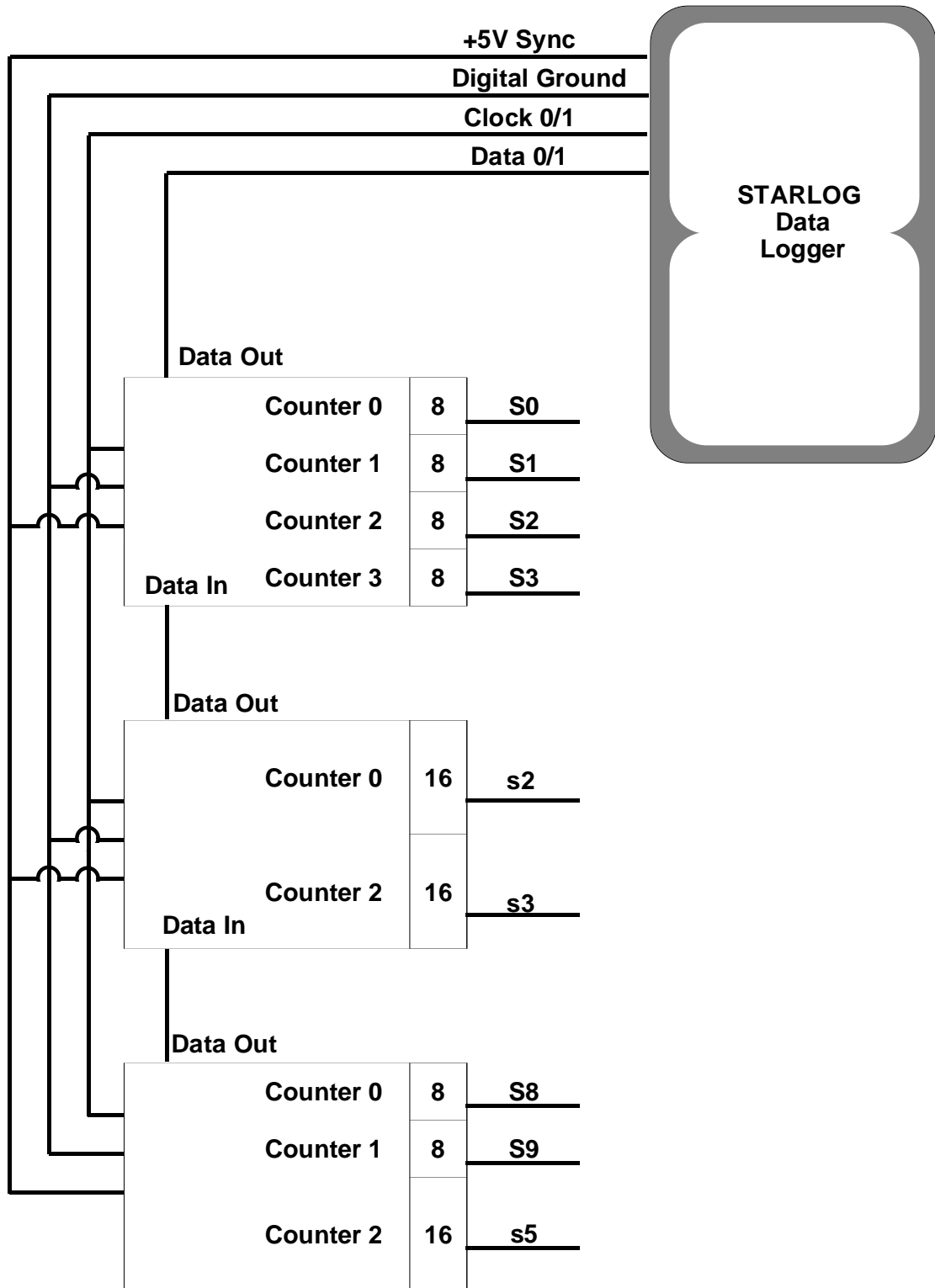

Connection Details and Scheme Channels for 3 Counter Modules

4.1. Limitations

Using STARLOG Software Version 2.1 and a Portable Data Logger, a maximum of 8 Modules may be used. Up to 4 Counter Modules may be "daisy-chained" on each Data Bus (Data 0 and Data 1). This totals 16 bytes of data.

Using STARLOG Software Version 2.1 and either a Macro Data Logger or a STARLOGGER, a maximum of 3¹/₂ Modules may be used. These Modules may be "daisy-chained" on Data Bus 0 only. This totals 14 bytes of data.

It is possible to use more Counter Modules with a single Data Logger by creating a custom scheme. Contact UNIDATA if you want to do this.

5. Specifications

Input:	suitable for potential free contacts and 5–12V DC signals up to 20 kHz
Output:	high speed serial
Enclosure:	UV stabilized polycarbonate, IP67
Size:	125mm H x 75mm W x 75mm D
Weight:	400 grams